

1 INTRODUCTION

1 WARNINGS & CAUTIONS

2 FUNCTIONS / FEATURES

3 VL110 ILLUSTRATIONS

3 HEAD UNIT

4 COMPONENTS

5 BUTTON FUNCTIONS

7 SCREEN DISPLAY SEQUENCE: BI-LEVEL MEMORY

8 HOW TO RECOGNIZE YOUR TORPEDO (T2X MODEL ONLY)

10 SETUP & PROGRAMMING

10 INITIAL SETUP

10 System Check

10 NOM SETUP

11 Setup: Dual Bike

11 Setup: Wheel Circumference

13 Setup: Service Timer

14 Setup: Speed Units

14 Setup: Temperature Units

14 Setup: Clock

15 Setup: Odometer

15 Setup: SmartLite ON/OFF

16 Setup: SmartLite Interval – From

16 Setup: SmartLite Interval – To

16 Exit

17 System Check

18 PRIMARY SCREEN MODES

18 UPPER SCREEN MODES

18 SPD/DST

19 RT/TT

20 AVG/MAX

20 SPD*/CAD*

21 LOWER SCREEN MODES

21 CLK/ODO

22 SPD/TMP

22 STP/IDS

23 SECONDARY SCREEN MODES

- 23 AVG CAD*/MAX CAD*
- 24 MAX TMP/MIN TMP

25 OTHER FEATURES

- 25 SLEEP MODE
- 25 AUTO FIRE UP
- 26 SMART LITE
- 26 DUAL BIKE MEMORY
- 26 SERVICE TIMER
- 27 SPEED COMPARATOR
- 27 LOW BATTERY WARNING
- 29 FREEZE FRAME MEMORY

30 RESET

- 30 RIDE DATA RESET
- 30 STOPWATCH & INTERMEDIATE DISTANCE RESET
- 30 ALL CLEAR TOTAL RESET

31 TROUBLE SHOOTING

33 TECHNICAL SPECIFICATIONS

34 WARRANTY POLICY

35 CUSTOMER SERVICE CENTERS

OPERATION

INTRODUCTION

EN

Thank you for purchasing a Vetta VL110 cycle computer. Please take time to familiarize yourself with all the functions of the VL110 model so you can take full advantage of its programs. And don't forget to store this manual in a safe place for future reference!

WARNINGS & CAUTIONS

- Vetta recommends that this product be installed only by a qualified bicycle retailer. Failure to read these instructions and/or improper installation of this device may void the warranty. If in doubt about any aspect of the installation or operation of this product, consult your local bicycle retailer for clarification.
- The Head Unit is splash proof and sealed to withstand wet weather conditions. Do not deliberately place it in water.
- Avoid leaving the Head Unit exposed to extremely hot or cold weather conditions.

FUNCTIONS / FEATURES

EN

	HD	WL	T2X
Smart Signal			●
Current / Average / Maximum Speed	●	●	●
Speed Comparator	●	●	●
Cumulative Odometer	●	●	●
Trip Distance	●	●	●
Intermediate Distance	●	●	●
12/24 Hour Clock	●	●	●
Stopwatch	●	●	●
Ride Time	●	●	●
Total Time	●	●	●
Service Timer	●	●	●

	HD	WL	T2X
Ambient Temperature	●	●	●
Maximum / Minimum Temperature	●	●	●
Dual Bike Memory	●	●	●
Freeze Frame Memory	●	●	●
Energy Saving Sleep Mode	●	●	●
Low Battery Warning (Head Unit)	●	●	●
Low Battery Warning LED Indicator (Torpedo)			●
Auto Fire Up - Auto Start up & Awake	●	●	●
NiteLite with SmartLite Function	●	●	●
Current / Average / Maximum Cadence			●

VL110 ILLUSTRATIONS

EN

HEAD UNIT

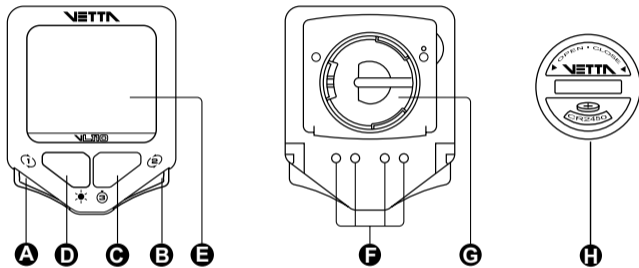

A Button 1

C Button 3

E Main Display

G Battery Compartment

B Button 2

D Button 4

F Contact Pins

H Battery Cap

COMPONENTS

EN

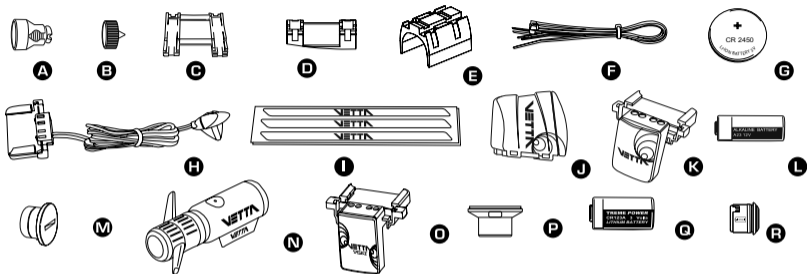

For All Models

- A** Bladed Spoke Magnet (SPD Magnet)
- B** Spacer
- C** Bracket Rubber Pad
- D** Bracket Rubber Pad (Riser Handlebar)
- E** Wireless Transmitter Shim/Torpedo Shim
- F** Zip-Ties
- G** Head Unit Battery (CR2450, 3-Volt)

For VL110 HD

- H** Wired Speed Sensor with Mounting Bracket
- I** Wire Securing Tape

For VL110 WL

- J** WL Wireless Speed Transmitter
- K** WL Wireless Speed Active Mount
- L** Wireless Transmitter Battery (A23, 12-Volt)
- M** Wireless Transmitter Battery Cap

For VL110 T2X

- N** Integrated T2X Torpedo
- O** Integrated T2X Active Mount
- P** Composite Cadence Magnet (CAD Magnet)
- Q** Torpedo Battery (CR123A, 3-Volt)
- R** Torpedo Battery Cap

BUTTON FUNCTIONS

EN

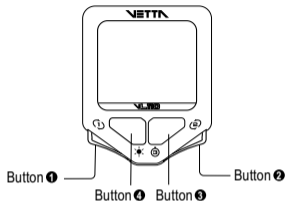

SETUP MODE

- Button **1** ♦ Sets digits or units
♦ Advances to the next item, screen or setting mode
- Button **2** ♦ Advances digits or toggles through units
♦ Hold for fast advance
♦ Resets RT to zero for Service Timer
- Button **3** ♦ Has no function in Initial Setup

OPERATING MODE

- Button **1** ♦ Scrolls through Lower Screen Modes
♦ Scrolls through Freeze Frame display screens
♦ Hold 2 seconds in SPD/TMP Mode to display Maximum and Minimum Temperature
♦ Hold 2 seconds in SPD/CAD* Mode to display Average and Maximum Cadence (*T2X model only)
- Button **2** ♦ Scrolls through Upper Screen Modes
♦ Press and hold 2 seconds in any Upper/Lower Screen Mode to activate Freeze Frame memory

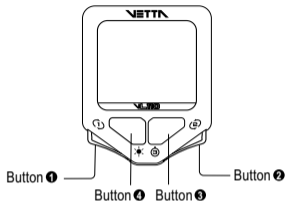

OPERATING MODE

- Button **3** ♦ Starts/stops RT/TT timers and Stopwatch
- ♦ Reset RT/TT timers and other ride data to zero
 - ♦ Exits NOM Setup and advances to NOM System Check and SPD/DST Mode
- Button **4** ♦ Turn on the NiteLite for 3 seconds
- Button **1** & **2** (simultaneously for 2 seconds with RT/TT Timers are off) :
- ♦ Hold both in the SPD/DST Mode to enter NOM Setup

For T2X model only

- Button **2** & **4** (simultaneously for 2 seconds with RT/TT Timers are off) :
- ♦ Hold both in the SPD/DST Mode to enter ID Learning Setup Mode

SCREEN DISPLAY SEQUENCE: BI-LEVEL MEMORY

EN

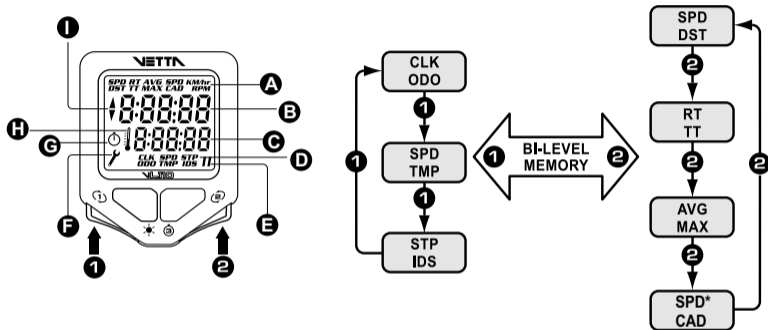

- A** Upper Screen Mode
- B** Upper Display
- C** Lower Display
- D** Lower Screen Mode
- E** Bicycle Icon
- F** Service Timer/ Low Battery Icon
- G** Stopwatch Icon
- H** Temperature Icon
- I** Speed Comparator Symbol

Remark: (*) Available until Upgrade to T2X model

HOW TO RECOGNIZE YOUR TORPEDO (T2X MODEL ONLY)

EN

1. For VL110 T2X or Upgrade to T2X models, your computer can ONLY recognize the Torpedo after it goes through the ID Learning procedure.
2. If your Torpedo is purchased as a complete set with the VL110 series computer, your computer has been programmed to recognize the Torpedo in the factory.
3. If a new Torpedo or Integrated T2X Active Mount is purchased for replacement, please follow the ID Learning Procedure.
4. If a complete set of Integrated T2X Mounting Kit is purchased for your 2nd bike, please make sure you had chosen Bike II in the NOM Setup Mode (see page 11, Section of Dual Bike Setup in NOM Setup), and follow the ID Learning Procedure.

ID LEARNING PROCEDURE

EN

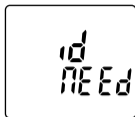

Step 1: Install the computer on the Integrated T2X Active Mount.

Step 2: After the screen display "id **NEEd**", press & hold the Torpedo's button for 3 seconds. The Light Ring Indicator of the Torpedo will turn on for 2 seconds in red.

Step 3: During the process, the computer will display "id **LEArn**" for 3 seconds.

Step 4: When done successfully, the computer will display "id **donE**" and gives 2 short beeps. The computer will go back to the screen last displayed.



FAILURE

If the computer always displays "id **NEEd**", you should check the alignments and spacings between the magnets and Torpedo and make sure that the Head Unit is completely snapped into position. If these checks do not solve the problem, talk to an authorized Vetta's Retailer or connect to www.vetta.com.



Important To re-activate the ID Learning Procedure, press & hold **2** & **4** simultaneously for 2 seconds with RT/TT timers are off.

SETUP & PROGRAMMING

EN

INITIAL SETUP

The computer will automatically go into the **Initial Setup Mode** after

1. New battery replacement, or
2. All Clear Total Reset

In the Initial Setup, riders can program the Basic Settings for the computer, the content of settings are same as NOM Setup for Basic Setting (see page 11, Section of NOM Setup for Basic Setting)

Important To change any values or correct any unit errors made during Initial Setup, you must re-enter the NOM Setup by pressing **1** and **2** simultaneously for 2 seconds in the SPD/DST Mode with the RT/TT timers deactivated.

SYSTEM CHECK

- After the last setting, the computer will automatically advance to System Check.
- System Check displays all value and unit settings chosen during Setup in sequence.
- Each screen in System Check appears for 5 seconds and blink.

NOM SETUP

After completed the Initial Setup, riders can change any values or correct any errors by re-entering the **NOM Setup**.

HOW TO ENTER THE NOM SETUP MODE?

1. Make sure RT/TT timers are off (press **3** in the RT/TT Mode and **⏸** will disappear)
2. Advance to the SPD/DST Mode by using **2**.
3. Press & hold **1** & **2** to enter the NOM Setup Mode.

Important Press **3** at any time to exit NOM Setup Mode and advance to System Check.

SETUP: DUAL BIKE

1. Press **2** to toggle between Bike 1 or Bike 2
2. Press **1** to select and advance to the next Setup Mode.

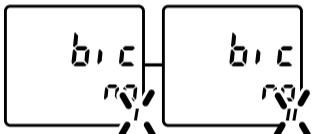

SETUP: WHEEL CIRCUMFERENCE

1. When the far right digit begins to flash, press **2** to scroll to the desired number. (see page 12, Section of WHEEL SIZE CALCULATION)
2. Press **1** to select this no. and advance to next flashing digit.
3. Repeat for each digit until the final digit.
4. Press **1** and advance to the next Setup Mode.

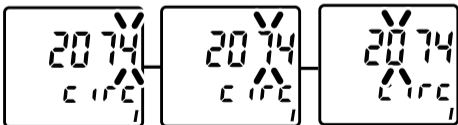

WHEEL SIZE CALCULATION

EN

Find your tire size and record the corresponding circumference measurement from the following chart lists.

TIRE SIZE	CIRC	TIRE SIZE	CIRC
700c x 38mm	2180	27" x 1-1/4"	2161
700c x 35mm	2168	27" x 1-1/8"	2155
700c x 32mm	2155	26" x 2.25"	2115
700c x 30mm	2145	26" x 2.1"	2095
700c x 28mm	2136	26" x 2.0"	2074
700c x 25mm	2124	26" x 1.9"	2055
700c x 23mm	2105	26" x 1.75"	2035
700c x 20mm	2074	26" x 1.5"	1985
700c Tubular	2130	26" x 1.25"	1953
650c x 23mm	1990	26" x 1.0"	1913
650c x 20mm	1945	20" x 1-1/4"	1618

If your wheel size is not on the chart, or if you want a more precise calibration, wheel circumference may be calculated as follows:

Step1: Measure the distance from the centre of the front wheel axle to the ground in millimetres. (1 inch =25.4 mm)

Step2: Multiply this distance by $6.2832(2\pi)$ and enter the result as the wheel size setting into the computer.

OR... Mark the tire and a spot on the floor. Roll the wheel forward one complete revolution until the tire mark touches the floor again and mark that spot. Measure the distance between the marks on the floor in millimetres and enter the result into the computer.

SETUP: SERVICE TIMER

Step 1: Service Timer Interval (in hour)

Service Timer will be disabled when Service Timer Interval is set to "0000"

1. When the lower far right digit begins to flash, press **2** to scroll to the desired number.
2. Press **1** to select this no. and advance to next flashing digit.
3. Repeat for each digit until the final digit.
4. Press **1** and advance to the Accumulated RT Reset Mode. (see Step 2)

Important In the Initial Setup, the Accumulated RT Reset Mode doesn't exist, press **1** will advance to the next Speed Units Setup Mode.

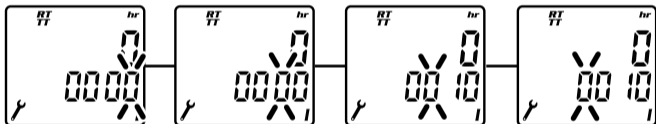

Step 2: Accumulated Ride Time (in hour)

To stop the Service Timer icon from flashing, reset the Accumulated RT to Zero.

When the upper digits begins to flash, press & hold **2** to reset Accumulated RT to Zero.

OR press **1** repeatedly to reserve the digits, and advance to the next Setup mode.

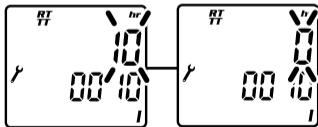

SETUP: SPEED UNITS

1. Press **2** to toggle between KM/hr or Mile/hr
2. Press **1** to select and advance to the next Setup Mode.



SETUP: TEMPERATURE UNITS

1. Press **2** to toggle between °C or °F
2. Press **1** to select and advance to the next Setup Mode.

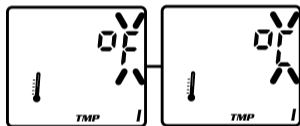

SETUP: CLOCK

1. Press **2** to toggle between 12hr or 24hr format, PM icon will appear only in the 12hr format.
2. Press **1** to select and advance to "hh:mm" setup.
3. When the far right digits begin to flash, press **2** to scroll to the desired number.
4. Press **1** to select this no. and advance to next flashing digit
5. Repeat for each digit until the final digit
6. Press **1** and advance to the next Setup Mode.

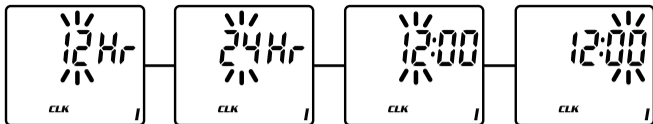

SETUP: ODOMETER

1. When the far right digit begins to flash, press **2** to scroll to the desired number
2. Press **1** to select this no. and advance to next flashing digit
3. Repeat for each digit until the final digit
4. Press **1** and advance to the next Setup Mode.



SETUP: SMARTLITE ON/OFF

1. Press **2** to toggle between ON or OFF
2. Press **1** to select. If set to ON, the computer will advance to the next Setup Mode.
3. If OFF, it will exit the Setup mode and advance to System Check.

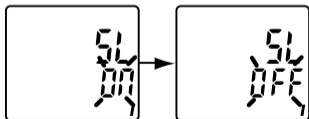

SETUP: SMARTLITE INTERVAL – FROM

1. Press **2** to scroll from 1:00 PM to 11:00 PM
2. Press **1** to select and advance to the next Setup Mode.



SETUP: SMARTLITE INTERVAL – TO

1. Press **2** to scroll from 1:00 AM to 11:00 AM
2. Press **1** to select and exit the Setup Mode and advance to System Check



EXIT

Press **3** at any time during the NOM Setup, and exit to System Check

Important If no buttons are pressed for approximately 5 minutes during Setup, the computer will automatically enter Sleep Mode and then return to the screen last displayed when reactivated.

SYSTEM CHECK

- After the last setting, the computer will automatically advance to System Check.
- System Check displays all value and unit settings chosen during Setup in sequence.
- Each screen in System Check appears for 5 seconds and blink.
- Press **⏏** at any time to exit System Check and advances to the SPD/DST Mode.

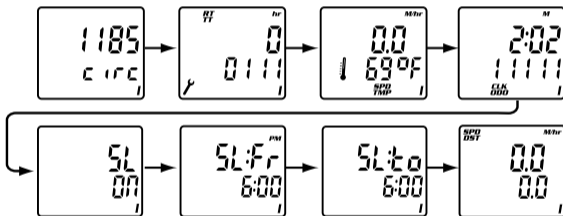

PRIMARY SCREEN MODES

IMPORTANT: For VL110 T2X or Upgrade to T2X models, your computer can ONLY recognize the transmitter—Torpedo after it goes through the ID Learning procedure (see page 8, Section of HOW TO RECOGNIZE YOUR TORPEDO)

UPPER SCREEN MODES

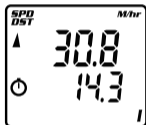

<i>UPPER/ LOWER DISPLAYS</i>	<i>DEFINITIONS</i>
<i>SPD</i>	<i>CURRENT SPEED (KM/hr or Mile/hr)</i>
<i>DST</i>	<i>CURRENT TRIP DISTANCE (KM or Mile)</i>

HOW TO OPERATE?

- Starts automatically when the wheels turn and TT timer is running (see page 19, Section of RT/TT Mode).
- Stops automatically when the wheels stop.

HOW TO RESET TRIP DISTANCE TO ZERO?

- Press **3** for 2 seconds in any Primary Screen Mode except STP/IDS, with the RT/TT timers turned off.

Important DST will automatically reset after the maximum trip distance (999.9) is achieved.



UPPER/ LOWER DISPLAYS

DEFINITIONS

RT

ACTUAL RIDE TIME IN THE TRIP

TT

*TOTAL ELAPSED TRIP TIME
FORM START TO FINISH*

HOW TO START THE TIMERS? Ⓞ

- If the timers have been reset to “0:00:00”, they will start automatically when the wheel rotates. (see HOW TO RESET THE TIMERS TO “0:00:00” below)
- If RT/TT timers had been stopped manually, and both of the RT/TT timers were not reset to zero, they must be restarted manually by pressing Ⓞ in RT/TT Mode.

Important TT timer must be active in order for the RT timer to accumulate Ride Time and for computer to calculate current ride.

HOW TO STOP?

- When the wheels stop, RT timer will pause, but TT timer will keep running to record the total elapsed trip time.
- OR stop both of the RT/TT timers manually by pressing Ⓞ in RT/TT Mode at the end of ride.

HOW TO RESET THE TIMERS TO “0:00:00”?

- Press Ⓞ for 2 seconds in any Primary Screen Mode except STP/IDS, with the RT/TT timers turned off.

☑ Tip:

If the bike is in motion and Button Ⓞ is held down in the RT/TT Mode with the timers deactivated, the ride timers reset to 0:00:00. When Button Ⓞ is released, both RT and TT will start with the next wheel input. This is a good way to begin timing a race or training ride with a rolling start.

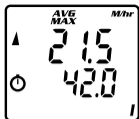

UPPER/ LOWER DISPLAYS	DEFINITIONS
AVG	AVERAGE SPEED (KM/hr or Mile/hr)
MAX	MAXIMUM SPEED (KM/hr or Mile/hr)

HOW TO OPERATE?

- Starts automatically when the wheels turn and TT timer is running (see page 19, Section of RT/TT Mode).
- Updated for every 0.1 miles or Km traveled.
- Stops automatically when the wheels stop.

HOW TO RESET TO ZERO?

- Press **3** for 2 seconds in any Primary Screen Mode except STP/IDS, with the RT/TT timers turned off.

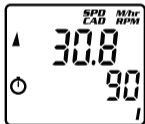

UPPER/ LOWER DISPLAYS	DEFINITIONS
SPD*	CURRENT SPEED (KM/hr or Mile/hr)
CAD*	PEDAL CADENCE IN REVOLUTIONS PER MINUTE (RPM)

*Available until Upgrade to T2X model

HOW TO OPERATE?

- Starts automatically when the wheels turn and TT timer is running (see page 19, Section of RT/TT Mode).
- Stops automatically when the wheels stop.

SECONDARY MODE

1. Press & hold **1** to read Average & Maximum Cadence (see page 23, Section of AVG CAD/MAX CAD Secondary Screen Mode)
2. Press **1** to exit.

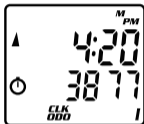
LOWER SCREEN MODES**UPPER/ LOWER DISPLAYS****DEFINITIONS***CLK**CURRENT TIME**ODO**ODOMETER, CUMULATIVE
DISTANCE (KM OR Miles)***HOW TO CHANGE THE CLOCK?**

- See page 14, Section of CLOCK Setup.

HOW DOES THE ODOMETER WORK?

- Automatically accumulate the trip distance when the wheels rotate and TT timer is running.

HOW TO RESET THE ODOMETER?

1. ALL CLEAR TOTAL RESET by press & hold **1**, **2** & **3** for 5 seconds in any Primary Screen Mode.
2. OR new battery replacement.
3. OR the ride distance exceeds the maximum limit, after which the Odometer will automatically reset to zero.

Important Odometer reading can be reinstalled by user.

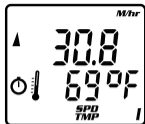

<i>UPPER/ LOWER DISPLAYS</i>	<i>DEFINITIONS</i>
------------------------------	--------------------

*SPD**CURRENT SPEED**TMP**CURRENT TEMPERATURE(°C OR °F)***HOW TO OPERATE?**

- The Temperature will be automatically updated once per minute.

HOW TO READ MAXIMUM & MINIMUM TEMPERATURE?

1. Press & hold **1** to read MAX TMP/MIN TMP (see page 24, Section of MAX TMP/MIN TMP Secondary Mode)
2. Press **1** to exit.

Important 1. Below zero readings are indicated by a minus sign (-).

2. The temperature reading can sometimes vary due to the computer head unit being heated by direct sunlight; which can heat the case hotter than the actual air temperature.

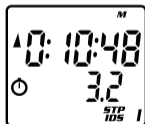

<i>UPPER/ LOWER DISPLAYS</i>	<i>DEFINITIONS</i>
------------------------------	--------------------

*STP**INDEPENDENT STOPWATCH OPERATES IN CONJUNCTION WITH THE RT/TT TIMES**IDS**INTERMEDIATE DISTANCE TRACKS AN INTERMEDIATE DISTANCE WITHIN A LONGER RIDE (FEET OR METERS)*

HOW TO START THE STOPWATCH? ⏸

- Press **3** to start.

HOW TO STOP?

- Press **3** to stop and freeze data for review.

HOW TO RESET THE STOPWATCH & INTERMEDIATE DISTANCE TO ZERO?

- Press **3** for 2 seconds.

Important IDS does not affect overall Trip Distance or current ride data, but it operates the same as the DST function.

SECONDARY SCREEN MODES

Important Flashing screen indicates the computer is displaying data in a Secondary Screen Mode.

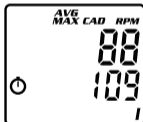

<i>UPPER/ LOWER DISPLAYS</i>	<i>DEFINITIONS</i>
<i>AVG CAD*</i>	<i>AVERAGE CADENCE (RPM)</i>
<i>MAX CAD*</i>	<i>MAXIMUM CADENCE (RPM)</i>

*Available until Upgrade to T2X model

HOW TO ENTER THE AVG CAD/MAX CAD SECONDARY SCREEN MODE?

- Press & hold **1** from SPD/CAD Mode.

HOW TO EXIT?

- Press **1** and exit to SPD/CAD Mode.

HOW TO RESET TO ZERO?

- Press **3** for 2 seconds in any Primary Screen Mode except STP/IDS, with the RT/TT timers turned off.



<i>UPPER/ LOWER DISPLAYS</i>	<i>DEFINITIONS</i>
<i>MAX TMP</i>	<i>MAXIMUM TEMPERATURE (°C OR °F)</i>
<i>MIN TMP</i>	<i>MINIMUM TEMPERATURE (°C OR °F)</i>

HOW TO ENTER THE MAX TMP/MIN TMP SECONDARY SCREEN MODE?

- Press & hold **1** from SPD/TMP Mode.

HOW TO EXIT?

- Press **1** and exit to SPD/TMP Mode.

HOW TO RESET TO ZERO?

- Press **3** for 2 seconds in any Primary Screen Mode except STP/IDS, with the RT/TT timers turned off.

OTHER FEATURES

SLEEP MODE

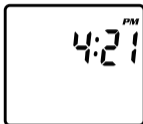

- To conserve battery life, the VL110 computer is programmed to enter a Sleep Mode after receiving no input from **buttons, wheel motion, cadence*** for 5 minutes. (* **T2X model only**)
- The screen displays only the time of day.
- All VL110 bicycle computers will wake up by either of input signal from **wheel/crank*** motion or any button is pressed. (* **T2X model only**)

AUTO FIRE UP

- Auto Start up & Awake without wasting extra battery run time of the computers.
- All VL110 bicycle computers will exit Sleep Mode automatically when they receive inputs from the **buttons or wheel/crank*** motion. (* **T2X model only**)
- If the RT/TT timers read zero (0:00:00), the computer automatically starts as soon as it receives input from the **wheels/crank*** motion. (* **T2X model only**)
- If you did not stop the RT/TT timers manually before the computer enter the Sleep Mode, the RT timer will automatically re-start as soon as it receives input from the wheels.

Important Any time the RT/TT timers are stopped manually and they are not reset to zero, they must be restarted manually by pushing **3** in the RT/TT Mode.

SMART LITE

EN

SmartLite will activate the NiteLite for 3 seconds between the user-defined period when any button is pressed. (see page 15, Section of SmartLite Setup)

DUAL BIKE MEMORY(I / II)

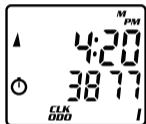

- VL110 can be calibrated for two bicycles. It will store separate Torpedo ID*, Wheel Size, Service Timer, Odometer, as well as different formats selected for Time, Speed and Distance. (* T2X model only)
- The current bike number (I or II) is always displayed in the lower right corner of the screen.
- To switch the computer quickly from Bike I to Bike II, go to the first screen in the NOM Setup Mode. (see page 11, Section of Dual Bike Setup)

SERVICE TIMER (⚒)

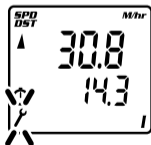

- Service Timer allows the rider to preset an exact number of riding hours during Setup
- Slow, flashing Wrench icon when service time limit has been reached.
- Rapid blinking Wrench icon indicates both low battery power in the Head Unit and expiration of the preset service time interval.
- To stop the Wrench icon from flashing (see page 13, Section of Service Timer Setup)

SPEED COMPARATOR (▲▼)

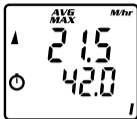

- The Speed Comparator symbols indicate whether current Speed is above or below Current Average Speed.
- A positive (▲) or negative (▼) symbol appears in the upper left part of the screen in all primary screen modes.
- The Speed Comparator symbols do not appear if Current Speed and Average Speed are the same.

LOW BATTERY WARNING (🔧)



FOR HD/WL MODELS:

- Stay-on Wrench icon indicates low battery power in the Head Unit.
- Rapid blinking Wrench icon indicates both low battery power in the Head Unit and expiration of the preset service time interval.



<i>UPPER/ LOWER DISPLAYS</i>	<i>DEFINITIONS</i>
<i>LO HEAD</i>	<i>Low Battery of Head Unit</i>
<i>LO SENS</i>	<i>Low Battery of Torpedo</i>
<i>LO ALL</i>	<i>Low Battery of Head Unit and Torpedo</i>

FOR T2X MODEL:

- Illuminate and stay “on” Wrench icon indicates low battery power in the Head Unit or Torpedo.
- Rapid blinking Wrench icon indicates both low battery power (either the Head Unit, Torpedo or both) and expiration of the preset service time interval.
- Low Battery Warning Messages will flip between the normal display for every 5 minutes.

Light Ring Indicator



Low Battery Indicator of Torpedo

- The Light Ring Indicator will blink in Red for 5 minutes when the wheels turn.

Important Replace the battery as soon as practical.

FREEZE FRAME MEMORY

- 3 primary screens (SPD/DST, RT/TT, AVG/MAX) will be frozen for review at any point during a race or training ride.

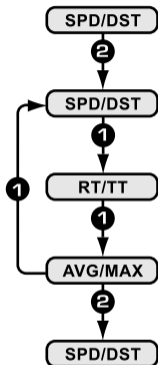

HOW TO SAVE?

1. Press & hold **2** in any Primary Screen Mode.
2. The screen will flash to indicate it has been frozen.
3. Press **1** to read & advance through the frozen screens.
4. Press **2** to exit.

HOW TO READ FROM THE HEAD UNIT?

At the end of ride, stop the RT/TT timers,

The last set will be frozen in their Primary & Secondary Screen Modes until they are cleared by RIDE DATA RESET (see page 30, Section of RIDE DATA RESET)

The last 2nd set can be reviewed by

1. Press & hold **2** in any Primary Screen Mode.
2. The screen will flash to indicate it has entered in the Freeze Frame Memory.
3. Press **1** to read & advance through the frozen screens.
4. Press **2** to exit.

RIDE DATA DISPLAYED IN FREEZE FRAME SCREEN

Current Speed	Total Time
Total Distance	Average Speed
Ride Time	Maximum Speed

RESET

EN

RIDE DATA RESET

1. Clear the current ride data (DST, RT, TT, AVG & MAX SPD, AVG & MAX CAD*, MAX & MIN TMP, STP, IDS) to Zero.
(*T2X model only)
2. Press **3** for 2 seconds in any Primary Screen Mode except STP/IDS, with the RT/TT timers turned off.

STOPWATCH AND INTERMEDIATE DISTANCE RESET

1. Press **3** in STP/IDS Mode to stop the Stopwatch.
2. Press **3** again for 2 seconds to reset the Stopwatch and Intermediate Distance to zero.

ALL CLEAR TOTAL RESET

1. Clear all settings entered in the Initial Setup or NOM Setup
2. Clear the current ride data to Zero from the screen.
3. Press & hold **1**, **2** & **3** for 5 seconds in any Primary Screen Mode.

- Important**
1. When the computer is cleared, the master screen will appear and show all LCD segments for 3 seconds.
 2. The computer will then automatically enter Initial Setup Mode to be reprogrammed.

- **Current speed-reading is erratic or does not appear.**
Check the alignment of the spoke magnet and sensor, and the distance between the two components. Realign the magnet and sensor with the spacer. Check to be sure RT and TT are activated.
- **Current speed-reading is erratic or does not appear. (VL110 HD)**
Inspect the wiring for any breaks or kinks. Replace the mounting bracket and sensor as needed.
- **Incorrect data appears on screen during operation.**
Accuracy of the Setup data may be a problem (wheel circumference setting, bike #, etc.). Review data in System Check mode and revise as needed.
- **Data display is extremely slow.**
Computer LCD does not operate well in extremely low temperatures. Operating range is: 0°C to 49°C or 32°F to 120°F. Return computer to warmer climate.
- **Screen is dark and display characters look “strange”.**
Computer screens are adversely affected if left in direct sunlight for extended periods of time. Move the computer into the shade until the screen recovers. No effect on data.
- **Screen reading is weak or fading.**
Symptom of interference or a weak battery.
Replace the battery.

- **Screen readings are erratic and read too high or too low.**
Symptom of a weak battery.
Replace the battery.
- **Screen “frozen”, no response to buttons.**
Symptom of a weak battery.
Replace the battery.
- **No display whatsoever.**
Battery is completely dead, or not installed.
Replace or install the battery.

TECHNICAL SPECIFICATIONS

EN

Current Speed (SPD)	0.0~120.0 KM/hr; 0.0~75.0 Mi/hr; +/-0.1 KM/hr or Mi/hr. Updated once per second.
Average Speed (AVG)	0.0~120.0 KM/hr; 0.0~75.0 Mi/hr; +/-0.1 KM/hr or Mi/hr. Updated once every 0.1 Miles or Km
Maximum Speed (MAX)	Limit: 120.0 KM/hr; 75.0 Mi/hr.
Odometer (ODO)	0~99999 km or miles.
Trip Distance (DST)	0.0~999.9 km or miles; +/- 0.1 km or mile.
Temperature Measure (TMP)	Range: 0°C~49°C or 32°F~120°F; +/- 1°C or °F.
Clock (CLK)	12 or 24 hr format, hours and minutes displayed.
Service Timer	Limit: 1~1999 hrs. max; +/-1 hr.
Stopwatch (STP)	Limit: 9:59:59 (10 hrs.); +/-1.0 seconds.

Intermediate Distance (IDS)	Range: 999.9 km or miles.
Ride/Total Time (RT/TT)	Limit: 9:59:59 (10 hours) displayed in hr/ min/sec. After 9:59:59, display restarts at "0:00:00".
*Cadence (T2X model only)	Range: 15~255 RPM; +/-1 RPM.
Operating Temperature	Range: 0°C~49°C or 32°F~120°F; +/- 1°C or °F.
Battery Type	Head Unit: CR2450, 3-Volt battery WL Wireless Speed Transmitter: A23, 12-Volt battery Integrated T2X Torpedo: CR123A, 3-Volt battery
Battery Run Time (1 hour training/ day, 7 days/week)	Head Unit: VL110 HD: 30 months VL110 WL: 20 months VL110 T2X: 18 months WL Wireless Speed Transmitter: 6 months Integrated T2X Torpedo: 24 months

WARRANTY POLICY

EN

ACUMEN INC. WARRANTS ALL **VETTA** (The Company) PRODUCTS AGAINST MANUFACTURER DEFECTS FOR A PERIOD OF 3 YEARS. Subject to the following limitations, terms and conditions, components will be free of manufacturing defects in materials and workmanship. The 3 year limited warranty is conditioned upon the components being used and operated in normal riding conditions. This warranty does not cover normal wear and tear (i.e. battery replacement, broken wire), rider abuse, acts of God, improper installation or product alteration. **This warranty is void if the components were not purchased (new) from or through an authorized VETTA retailer or dealer, examples of unauthorized dealers are online auction sites or online retailers that do not offer service.**

ACUMEN INC. at its sole discretion will repair or replace items at its own cost. Users are responsible for all freight and shipping charges, when returning items for warranty service.

ACUMEN INC. will pay the freight when returning serviced items, via USPS or UPS to consumers or dealers, once the item(s) has been repaired or replaced.

REQUIREMENTS FOR WARRANTY SERVICING

1. Prior to shipping an item back, you must first obtain a Return Authorization Number (s) (RA#). Each item being returned must have an individual RA#.
2. To obtain an RA #, you must either contact the retailer where the product was originally purchased from, or contact VETTA directly at customerservice@vetta.com.
3. For trouble shooting purposes, we request that the complete unit with packaging be returned to **ACUMEN INC.** unless otherwise stated by **VETTA** representative.

ITEMS TO BE INCLUDED IN RETURNS

1. The defective product(s)
2. A letter clearly stating the problem(s) with the returned item(s).
3. Copy of the original sales receipt showing proof of purchase date.
4. The Company is not responsible for loss or additional damages while in transit to **ACUMEN INC.**
5. Clearly mark the RA# on the outside of the return packaging. All items without an RA # will be refused and returned to the return address on the package.

The Company shall not be held responsible for replacing items with new items for greater than the amount of the original item purchase price. This limited warranty does provide the original owner with certain legal rights and recourse. The original owner may possess other rights or recourse, depending on the state or country. Please check the web to help answer any question and service manual.

CUSTOMER SERVICE CENTERS

Acumen Inc.

101A Executive Dr., Suite 100, Sterling, VA 20166, USA.

Acumen Europe BV

Splijtbakweg 117, 1333 HJ, Almere, The Netherlands.

E-Mail: customerservice@vetta.com

Website: www.vetta.com