



Acumen Inc.  
www.vetta.com  
©2005 All Rights Reserved

RT33 RT55 RT77 RT88



REV. 8.0

ENGLISH

## WARNINGS & CAUTIONS

- Vetta cycle computers are sophisticated electronic instruments. Vetta recommends that this product be installed only by a qualified bicycle retailer. Failure to read these instructions and/or improper installation of this device may void the warranty. **If in doubt about any aspect of the installation or operation of this product, consult your local bicycle retailer for clarification.**
- The head unit is water resistant and sealed to withstand wet weather conditions. However, do not deliberately place it in water.
- Avoid leaving the head unit exposed to extremely hot weather conditions.
- Vetta encourages you to ride safely. Wear a helmet every time you ride, use front and rear lights at night, and always keep your eyes on the road ahead of you.

## HEAD UNIT: FRONT

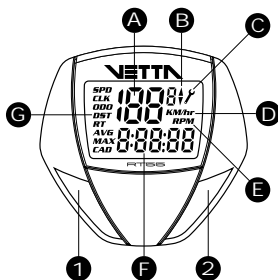

- A Upper Display (Speed)
- B Speed Comparator Icon
- C Service Timer Icon
- D Speed/Distance Units
- E RPM Indicator
- F Lower Display
- G Function Icons

- 1 Set/Select Button (Left)
- 2 Mode/Advance Button (Right)

## HEAD UNIT: REAR

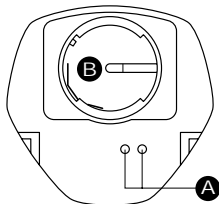

- A Contact Points
- B Battery Compartment
- C Battery Cover

## COMPONENT ILLUSTRATIONS

- 1 Head Unit Battery (CR2032 - 3V)
- 2 WL Wireless Speed Transmitter Battery (A23 - 12V)
- 3 Wired Cadence Sensor (RT77)
- 4 Cadence Magnet (RT77)
- 5 WL Wireless Speed Transmitter (RT88)
- 6 Spoke Magnet
- 7 Wire Securing Tape
- 8 Wired Speed Sensor
- 9 Mounting Bracket Pad
- 10 Riser Handle Bar Bracket (You may choose 9 or 10 according to the style of your bicycle handlebar.)
- 11 Zip Ties
- 12 Wireless Mount (RT88)
- 13 Wired Mount
- 14 Spacer
- 15 Transmitter Mounting Pad

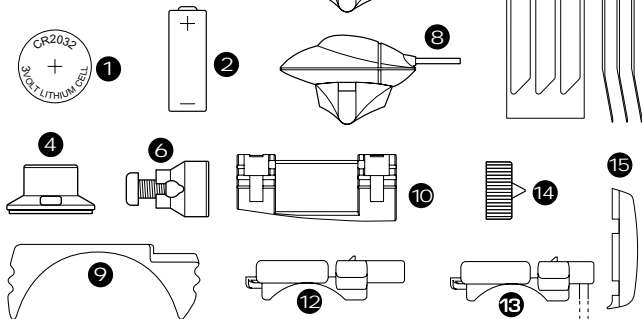

## BATTERY INSTALLATION

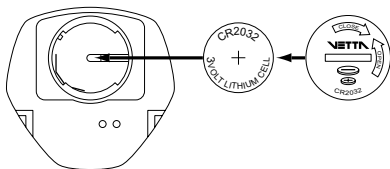

## MAIN UNIT SETUP

All RT series computers are programmed to enter the Setup mode after battery installation. In Set-Up, Button #1 is used to select or set a value and to advance to the next digit or screen mode. Button #2 is used to switch between settings and to increase values.

### SET 12/24 CLOCK



Press Button #2 to switch between flashing "12" and "24" hour formats. Press Button #1 to select desired format and advance to time setting.

### SET TIME

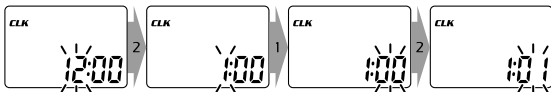

To set the time in CLK mode: Press button #2 to advance hour digits to correct hour (hold button for rapid advance). Press Button #1 to select and advance to minutes setting. Press Button #2 to advance minute digits and press Button #1 to select. **(To change the CLK format, time or service time interval, press and hold Buttons #1 and #2 simultaneously for 2 seconds in the SPD/CLK screen mode until "12/24" hour format digits flash).**

### SET SERVICE TIMER

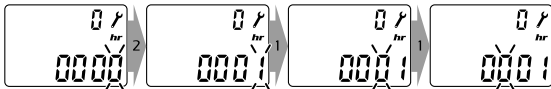

Press Button #2 to advance hour digits to desired total hours and press Button #1 to select and advance (Maximum hour setting = 1999 hours).

### SET SPEED/DISTANCE SCALE

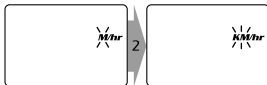

Press Button #2 to switch between "M/hr" and "KM/hr" and Button #1 to select desired units and advance. **(To change units in SPD/ODO screen mode, press and hold Buttons #1 and #2 simultaneously for 2 seconds until "M/hr" begins to flash).**

### SET WHEEL SIZE

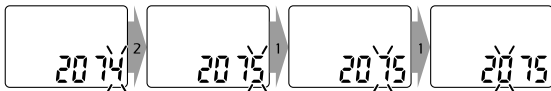

Default wheel circumference setting is 2074mm. Choose correct wheel circumference figure from Wheel Reference Chart. **Press Button #2 to advance digits as needed and Button #1 to select and advance.** (Range: 0050-2999mm).

| TIRE SIZE    | CIRC | TIRE SIZE         | CIRC | TIRE SIZE         | CIRC |
|--------------|------|-------------------|------|-------------------|------|
| 700c x 38mm  | 2180 | 650c x 23mm       | 1990 | 26" x 1.75"       | 2035 |
| 700c x 35mm  | 2168 | 650c x 20mm       | 1945 | 26" x 1.5"        | 1985 |
| 700c x 32mm  | 2155 | 27" x 1-1/4"      | 2161 | 26" x 1.25"       | 1953 |
| 700c x 30mm  | 2145 | 27" x 1-1/8"      | 2155 | 26" x 1.0"        | 1913 |
| 700c x 28mm  | 2136 | 26" x 2.3"        | 2135 | 24" x 1.9"/ 1.95" | 1916 |
| 700c x 25mm  | 2124 | 26" x 2.25"       | 2115 | 20" x 1-1/4"      | 1618 |
| 700c x 23mm  | 2105 | 26" x 2.1"        | 2095 | 16" x 2.0"        | 1253 |
| 700c x 20mm  | 2074 | 26" x 2.0"        | 2074 | 16" x 1.95"       | 1257 |
| 700c Tubular | 2130 | 26" x 1.9"/ 1.95" | 2055 | 16" x 1.5"        | 1206 |

If your wheel size is not on the chart, or if you want a more precise calibration, wheel circumference may be calculated as follows:

Mark the tire and a spot on the floor. Roll the wheel forward one complete revolution until the tire mark touches the floor again and mark that spot. Measure the distance between the marks on the floor in millimeters and enter the result into the computer. (1 inch = 25.4mm)

## SET ODOMETER



Press Button #2 to advance digits to previous mileage reading (after battery change). Press Button #1 to select and advance to next digit. After final selection, computer will exit Setup and enter SPD/CLK screen mode (Maximum setting: 99999).

## PRIMARY FUNCTIONS

**SPD** RT 33|55|77|88



Speed is shown at all times on upper display. It is accurate to 0.1 M/hr or KM/hr and the maximum reading is 139.9 M/hr or 199.9 KM/hr.

**CLK** RT 33|55|77|88



Time is displayed in user-selected 12 or 24 hour formats. **(To change the CLK format, time or service time interval, press and hold Buttons #1 and #2 simultaneously for 2 seconds in the SPD/CLK screen mode until "12/24" hour format digits flash).**

**ODO** RT 33|55|77|88



The odometer displays distance to 99999 Miles or Kilometers (1.0 mile/km). User selectable ODO setting in Setup mode. Note: Odometer units (initialized during Setup). **(To change units in SPD/ODO screen mode, press and hold Buttons #1 and #2 simultaneously for 2 seconds until "M/hr" begins to flash).**

**DST** RT 33|55|77|88



Displays trip distance of current ride to a maximum of 999.9 miles or kilometers (0.1 mile/km). **To reset trip distance DST (+ MAX, AVG, RT, AVG/CAD, MAX/CAD) to zero in normal operation, hold both buttons simultaneously for two seconds in SPD/DST screen mode.**

RT

RT 55|77|88

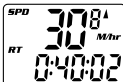

Displays actual, cumulative ride time to 9:59:59. **Reset to zero manually by pressing and holding Buttons #1 and #2 simultaneously for two seconds in the SPD/DST screen mode.**

AVG

RT 55|77|88



Average Speed is displayed in the SPD/AVG screen mode and reads to within 0.1 miles or kilometers per hour. **Reset to zero manually by pressing and holding Buttons #1 and #2 simultaneously for two seconds in the SPD/DST screen mode.**

MAX

RT 55|77|88



Maximum Speed is displayed in the SPD/MAX screen mode and reads to within 0.1 miles or kilometers per hour. **Reset to zero manually by pressing and holding Buttons #1 and #2 simultaneously for two seconds in the SPD/DST screen mode.**

CAD

RT 77



Cadence is displayed in the SPD/CAD screen mode and measures revolutions per minute (RPM) of the crank. The RPM indicator lights when the CAD function is displayed.



RT 55|77|88



Speed Comparator: Arrow symbols indicate if current speed is slower ▼ or faster ▲ current average speed.



RT 33|55|77|88



Service Timer: Blinking wrench icon alerts rider when scheduled maintenance is required for suspension shocks, chains or other components. Elapsed riding time and current Service Timer setting can be viewed on upper and lower displays in Setup mode. **To view or change Service Timer interval, CLK format and time setting, press and hold Buttons #1 and #2 for 2 seconds in the SPD/CLK screen mode until "12/24" hour format digits flash. To reset ride time to "0", press Button #2 when elapsed time digits are flashing during Setup. To disable Service Timer, enter "0" hours as Service Time Interval in Setup.**

## SPECIAL FEATURES

SLEEP MODE

RT 33|55|77|88

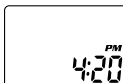

To conserve battery life, computer enters Sleep Mode after 5 minutes without input from buttons or speed sensor and displays the time. **Computer exits Sleep Mode and returns to screen last displayed with input from buttons (RT 33/55/77/88) or wheel (RT 33/55/77).**

## FREEZE FRAME MEMORY RT 55|77|88

Rider can freeze Distance, Ride Time, Average Speed and Maximum Speed readings at any time by pressing Button #1 for two seconds while in the SPD/DST or SPD/RT screen modes. Display flashes to indicate it has been frozen. Saved data can be scrolled and reviewed by pressing Button #2. Press Button #1 to return to DST or RT screens.



## ALL CLEAR RESET RT 33|55|77|88

All Clear Reset: Remove battery and reinstall. When you remove the battery all data and all time and odometer settings will be cleared. When battery is reinstalled, computer will automatically enter the Setup program.

## RT 77 SECONDARY FUNCTIONS

Secondary screen functions include Average Cadence and Maximum Cadence. To access, press and hold Button #1 while in the SPD/CAD screen mode. Press Button #2 to switch between AVG/CAD and MAX/CAD readings. Press Button #1 to return the primary SPD/CAD screen mode.

### AVG/CAD RT 77



Average Cadence is displayed in the AVG/CAD screen mode. It is calculated by dividing total revolutions by total ride time. **Reset to zero manually by pressing and holding Buttons #1 and #2 simultaneously for two seconds in the SPD/DST screen mode.**

### MAX/CAD RT 77



Maximum Cadence is displayed in the MAX/CAD screen mode. It is updated once per second based on current RT and Cadence readings. **Reset to zero manually by pressing and holding Buttons #1 and #2 simultaneously for two seconds in the SPD/DST screen mode.**

## INSTALLATION PROCEDURES

### WIRED SPEED SENSOR & MAGNET RT 33|55|77

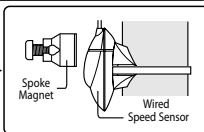
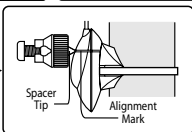
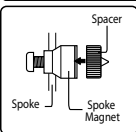
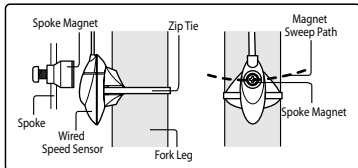
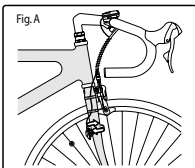

Attach the wired speed sensor with the zip-tie supplied and tighten the spoke magnet to the bicycle. Adjust the sensor and magnet spacing with the spacer. Remove the spacer after snugging the zip-tie down to hold the sensor in its final position. (See Figures above)

## WIRED CADENCE SENSOR & MAGNET

RT 77

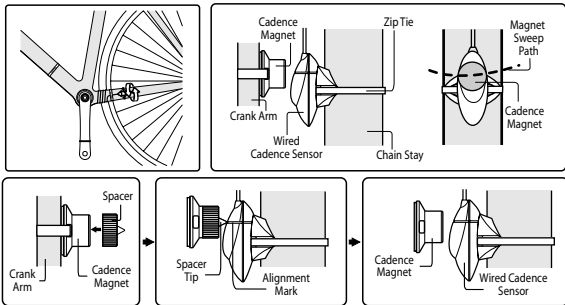

**RT77 only** - Attach the wired cadence sensor and cadence magnet with the zip-ties supplied to the bicycle. Adjust the sensor and magnet spacing with the spacer. Remove the spacer after snugging the zip-tie down to hold the sensor in its final position. (See Figures above)

## WL WIRELESS SPEED TRANSMITTER & MAGNET

RT 88

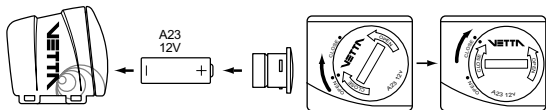

WL Wireless speed transmitter uses an A23 12V battery. Install the battery as shown: remove cap, install battery with positive (+) side up, replace battery cap.

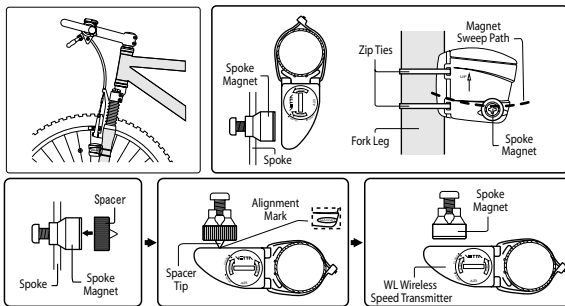

**RT88 only** - Attach the WL wireless speed transmitter with the zip-ties supplied and tighten the spoke magnet to the bicycle. Adjust the transmitter and magnet spacing with the spacer. Remove the spacer after snugging the zip-ties down to hold the transmitter in its final position. (See Figures above)

## MOUNTING BRACKET & HEAD UNIT

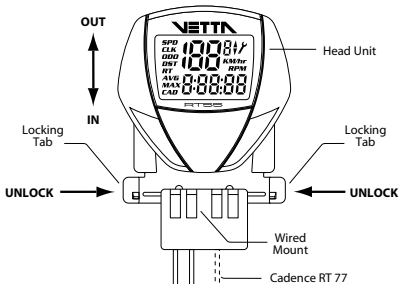

Attach mounting bracket.

**Note:** Be sure to leave enough slack in the wire to accommodate the movement of fork and handlebars. Tighten mounting bracket as needed. (See fig. "A") Slide main unit into bracket as shown (left) until it clicks into position. Remove by pressing in the two locking tabs as shown. Secure wire with tape supplied and by winding it around cables.

## INSTALLATION TESTS

Once installation is complete, the computer should be tested to make sure it is working properly.

### To test speed installation:

Step 1: Advance the computer to the SPD screen mode using Button #2.

Step 2: Pick up the front of the bicycle and spin the front wheel. The computer should display a speed reading within 2-3 seconds.

If there is no speed reading, check the alignment and spacing between the magnet and sensor/transmitter. Make sure that the head unit is completely locked into position and **the handlebar mount is not over tightened**. If this check does not solve the problem, talk to your Vetta Retailer or connect to [www.vetta.com](http://www.vetta.com).

### To test cadence installation:

Turn the crank backwards or ride the bike a short distance. After a few revolutions, a cadence reading should appear on the lower line of the SPD/CAD display. If there is no cadence reading, check the alignment and spacing between the magnet and sensor.

**IMPORTANT:** Following the installation tests above, make sure that the spoke magnet locking screw and all zip ties are properly tightened. **CAUTION: Do not over tighten!**

## PROBLEM/ITEMS TO CHECK/SOLUTION

- **Current speed reading is erratic or does not appear.**  
Check the alignment of the wheel magnet and sensor, and the distance between the two components. Realign the magnet and sensor with the spacer.
- **Current speed reading is erratic or does not appear.**  
Inspect the wiring for any breaks or kinks. Replace mounting bracket and sensor as needed.
- **Incorrect data appears on screen during operation.**  
Accuracy of the Setup data may be a problem (wheel size setting, etc.).
- **Data display is extremely slow.**  
Computer LCD does not like extremely low temperatures. Operating range is: 0°C to 50°C or 32°F to 122°F. Return the computer to a warmer climate.

- **Screen is dark and display characters look "strange".**  
Computer screens do not like to be left in direct sunlight for extended periods of time. Move the computer into the shade until the screen recovers. No effect on data.
- **Screen reading is weak or fading.**  
Symptom of a weak battery. Replace the battery.
- **Screen readings are erratic and read too high or too low.**  
Symptom of a weak battery. Replace the battery.
- **Screen "frozen", no response to buttons.**  
Symptom of a weak battery. Replace the battery.
- **No display whatsoever.**  
Battery is completely dead, or not installed. Replace or install the battery.

## WARRANTY RETURN & REPAIR POLICY

Acumen Inc, warrants all Vetta products, to the original purchaser, to be free of defects in materials or workmanship for a period of three years from the original date of purchase. Acumen Inc will, at its sole discretion, repair or replace any product deemed defective. This express warranty is in lieu of all other warranties, either expressed or implied. Any warranties of merchantability or fitness for a particular purpose are limited to the three years duration of the above express warranty. Acumen Inc will not be held liable for any incidental or consequential damages.

If you ever experience a problem with the function of your Vetta RT cycle computer, please contact or visit your local Authorized Acumen Inc Dealer for assistance.

Should you experience a problem with your Vetta RT cycle computer that cannot be solved by your local Acumen Inc Dealer, please follow these simple steps to assure quick and efficient processing of your claim.

- Step 1:** Contact the appropriate Acumen Inc Customer Service Center listed below for help and to obtain a Return Authorization Number (RA Number).
- Step 2:** Send the unit back to the appropriate Acumen Inc Customer Service Center, together with the original copy of your purchase receipt and a detailed explanation of the problem that you are experiencing. Please be sure to write the Return Authorization Number (RA Number) on your return package.

## ACUMEN INC CUSTOMER SERVICE CENTERS

### **Acumen Inc.**

101A Executive Dr., Suite 100,  
Sterling, VA 20166, USA.

### **Acumen Europe BV**

Splijtbakweg 117, 1333 HJ, Almere,  
The Netherlands.

Email: [customerservice@vetta.com](mailto:customerservice@vetta.com)

Website: [www.vetta.com](http://www.vetta.com)