

2003

JUDY

OWNER'S MANUAL



C AND TT

FEATURES / AUSSTATTUNG / CARACTERÍSTICAS / CARACTÉRISTIQUES / CARATTERISTICHE / EIGENSCHAPPEN / CARACTERÍSTICAS / 特徴

Judy C

- 80 or 100 mm Travel / 80 oder 100 mm Federweg / 80 o 100 mm de recorrido / Débattement de 80 ou 100 mm / Escursione 80 o 100 mm / 80 of 100 mm bewegingsruimte / Curso de 80 ou 100 mm / **トラベル量 80 または 100mm**
- Dual Stage, coil and elastomer spring system / Dual Stage, Stahl- und Elastomer-Federsystem / Sistema de muelles de Dual Stage, helicoidal y elastómero / Système à deux étages, à ressorts hélicoïdaux et en élastomère / Dual Stage, sistema elastico con molla ed elastomero / Dual Stage, spiraal- en elastomeer veersysteem / Sistema Dual Stage com amortecedor de mola e elastómero / **コイル/エラストマー二段階スプリングシステム**
- Preload Adjustment / Einstellbare Vorspannung / Ajuste de precarga / Réglage de la précharge / Regolazione del precarico / Instelling voorbelasting / Ajuste de precarregamento / **プレロード調節**
- Magnesium Die Cast Lower Tube / Unteres Rohr aus gespritztem Magnesium / Tubo inferior de magnesio vaciado / Tube inférieur en magnésium, moulé sous pression / Fusione monopezzo foderi in magnesio / Magnesium gegoten onderbuis / Tubo inferior moldado de magnésio / **マグネシウム・ダイカスト・ローアーチューブ**

Judy TT

- 80 mm Travel / 80 mm Federweg / 80 mm de recorrido / Débattement de 80 mm / Escursione 80 mm / 80 mm bewegingsruimte / Curso de 80 mm / **トラベル量 80 mm**
- Dual Stage, coil and elastomer spring system / Dual Stage, Stahl- und Elastomer-Federsystem / Sistema de muelles de Dual Stage, helicoidal y elastómero / Système à deux étages, à ressorts hélicoïdaux et en élastomère / Dual Stage, sistema elastico con molla ed elastomero / Dual Stage, spiraal- en elastomeer veersysteem / Sistema Dual Stage com amortecedor de mola e elastómero / **コイル/エラストマー二段階スプリングシステム**
- Preload Adjustment / Einstellbare Vorspannung / Ajuste de precarga / Réglage de la précharge / Regolazione del precarico / Instelling voorbelasting / Ajuste de precarregamento / **プレロード調節**

Congratulations! You have the best in suspension components on your bicycle! This manual contains important information about the safe operation and maintenance of your fork. To insure that your RockShox fork performs properly, we recommend that you have your fork installed by a qualified bicycle mechanic. We also urge you to follow our recommendations to help make your bicycling experience more enjoyable and trouble-free.

I M P O R T A N T

Consumer Safety Information

1. The fork on your bicycle is designed for use by a single rider, on mountain trails, and similar off-road conditions.
2. Before riding the bicycle, be sure the brakes are properly installed and adjusted. If the brakes do not work properly, the rider could suffer serious and/or fatal injuries.
3. Your fork may fail in certain circumstances, including, but not limited to, any condition that causes a loss of oil; collision or other activity bending or breaking the fork's components or parts; and extended periods of non-use. Fork failure may not be visible. Do not ride the bicycle if you notice bent or broken fork parts, loss of oil, sounds of excessive topping out, or other indications of a possible fork failure, such as loss of shock absorbing properties. Instead, take your bike to a qualified dealer for inspection and repair. In the event of a fork failure, damage to the bicycle or personal injury may result.
4. Always use genuine RockShox parts. Use of aftermarket replacement parts voids the warranty and could cause structural failure to the shock. Structural failure could result in loss of control of the bicycle with possible serious and/or fatal injuries.
5. Use extreme caution not to tilt the bicycle to either side when mounting the bicycle to a carrier by the fork drop-outs (front wheel removed). The fork legs may suffer structural damage if the bicycle is tilted while the drop-outs are in the carrier. Make sure the fork is securely fastened down with a quick release. Make sure the rear wheel is fastened down when using ANY bike carrier that secures the fork's drop-outs. Not securing the rear can allow the bike's mass to side-load the drop-outs, causing them to break or crack. If the bicycle tilts or falls out of its carrier, do not ride the bicycle until the fork is properly examined for possible damage. Return the fork to your dealer for inspection or call RockShox if there is any question of possible damage (See the International Distributor List). A fork leg or drop-out failure could result in loss of control of the bicycle with possible serious and/or fatal injuries.
6. Only mount cantilever-type brakes to the existing brake posts. Forks with hangerless style braces are only designed for 'V'- style or hydraulic cantilever brakes. Do not use any cantilever brake other than those intended by the brake manufacturer to work with a hangerless brace. Do not route the front brake cable and/or cable housing through the stem or any other mounts or cable stops. Do not use a front brake cable leverage device mounted to the brace.
7. Observe all owner's manual instructions for care and service of this product.

ROCKSHOX FORKS ARE DESIGNED FOR COMPETITIVE OFF-ROAD RIDING AND DO NOT COME WITH THE PROPER REFLECTORS FOR ON-ROAD USE. YOUR DEALER SHOULD INSTALL PROPER REFLECTORS TO MEET THE CONSUMER PRODUCT SAFETY COMMISSION'S (CPSC) REQUIREMENTS FOR BICYCLE STANDARDS IF THE FORK IS GOING TO BE USED ON PUBLIC ROADS AT ANY TIME.

INSTALLATION

It is extremely important that your RockShox fork is installed correctly by a qualified bicycle mechanic. Improperly installed forks are extremely dangerous and can result in severe and/or fatal injuries.

1. Remove the existing fork from the bicycle and the crown race from the fork. Measure the length of the fork steerer tube against the length of the RockShox steerer tube. The RockShox steerer tube may need cutting to the proper length. Make sure there is sufficient length to clamp the stem (refer to the stem manufacturer's instructions).



WARNING

DO NOT ADD THREADS TO ROCKSHOX THREADLESS STEERERS. THE STEERER TUBE CROWN ASSEMBLY IS A ONE-TIME PRESS FIT. REPLACEMENT OF THE ASSEMBLY MUST BE DONE TO CHANGE THE LENGTH, DIAMETER OR HEADSET TYPE (THREADED OR THREADLESS).

DO NOT REMOVE OR REPLACE THE STEERER TUBE. THIS COULD RESULT IN THE LOSS OF CONTROL OF THE BICYCLE WITH POSSIBLE SERIOUS AND/OR FATAL INJURIES.

2. Install the headset crown race (29.9mm for 1 1/8" steerers) firmly against the top of the fork crown (fig. 1). Install the fork assembly on the bike. Adjust the headset until you feel no play or drag.
3. Install the brakes according to the manufacturer's instructions and adjust brake pads properly. Use the fork only with V-type or hydraulic cantilever brakes mounted to the existing brake posts or disc style brakes mounted through the provided mounting holes. Do not use any cantilever brake other than those intended by the brake manufacturer to work with a hangerless brace.
4. Adjust the front wheel quick release to clear the dropout's counter bore. The quick release nut must be tightened after the wheel is properly seated into the dropout's counter bore. Make sure four or more threads are engaged in the quick release nut when it is closed. Orient the quick release lever in front of and parallel to the lower tube in the locked position.
5. Keep in mind tire clearance as you choose tires. Maximum size is 2.3" wide or 345 mm radius installed. Be sure to check this radius whenever you change tires. To do this, remove the top caps and spring stack assemblies and compress the fork completely to make sure at least 5mm of clearance exists between the top of the tire and the bottom of the crown. Exceeding maximum tire size will cause the tire to jam against the crown when the fork is fully compressed.

PERFORMANCE TUNING (ADJUST MODELS ONLY)

RockShox forks can be tuned for your particular weight, riding style, and terrain.

Setting Sag

Judy forks are designed to sag when you are sitting on your bike. Sag is the compression of the fork caused by the rider's weight. Proper sag allows the front wheel to follow the contour of the terrain as you ride.

Sag is adjusted by turning the top cap preload adjuster (fig 2). Turning the adjuster clockwise increases spring preload (i.e. stiffening the spring) decreasing sag. Turning the adjuster counter clockwise decreases spring preload which increases sag.

<u>Model</u>	<u>Fork Travel</u>	<u>Sag</u>
Judy TT/C	80 mm	13-20 mm
Judy TT/C	100 mm	18-25 mm

To measure sag, install a zip tie on the upper tube of the fork flush against the dust wiper. Sit on the bike with normal riding apparel. Step off the bike, and measure the distance between the dust wiper and the zip tie. This is your sag.

MAINTENANCE

To maintain the high performance, safety, and long life of your fork, periodic maintenance is required. If you ride in extreme conditions, maintenance should be performed more frequently. Recommended intervals for maintenance are listed below.

Before Every Ride

Check the other components on your bicycle in accordance with the manuals supplied by the manufacturer to make sure they are in working order.

After every ride

Clean and dry the fork taking care not to get water in the upper tube/lower tube junction.

After Every 8 Hours of Riding

- Lift boots from lower tube. Wipe exterior surfaces, resi-wiper seal area, and upper tubes. Apply 2-3 drops of Teflon-based oil to the upper tube/lower tube junction.
- Refit the fork boots into the resi-wiper seal groove using a small blade screwdriver. Engage the boot with Resi-wiper seal groove at the rear and rotate the boot around the upper tube to fully engage its lower edge behind the brace. A small amount of oil on the mating surface helps.
- Check top cap assemblies, brake posts, and shaft bolts for proper torque using the following values:

Torque Tightening Values

Top Caps	40 in-lb
Brake Posts	80 in-lb
Shaft Bolts	50 in-lb

After Every 20 Hours of Riding

- Disassemble the fork. This procedure should be done by a qualified mechanic with proper tools. The mechanic should clean the internal parts using a suitable solvent, inspect all parts for damage, and replace any parts that are damaged.
- Lubricate the internal parts including the springs, washers, guide washers, and other associated parts using non-lithium, bicycle bearing type grease.
- Check for bushing play by wiggling the upper half of the fork in relation to the lower sliding portion of the fork. RockShox uses bushings that are extremely durable. If bushing play is felt, contact your local RockShox dealer to arrange for bushing replacement.

* FOR MORE DETAILED SERVICE INFORMATION, SEE OUR WEBSITE AT WWW.ROCKSHOX.COM.

WARRANTY

RockShox, Inc. warrants its products for a period of one year from original date of purchase to be free from defects in materials or workmanship. Any RockShox product that is returned to the factory and is found by RockShox to be defective in materials or workmanship will be repaired or replaced at the option of RockShox, Inc. This warranty is the sole and exclusive remedy. RockShox shall not be held liable for any indirect, special, or consequential damages.

The warranty does not apply to products which have not been properly installed and adjusted according to RockShox installation instructions. The warranty does not cover any product that has been subject to misuse or whose serial number has been altered, defaced or removed. This warranty does not apply to damage to the product caused by a crash or abuse of the product or any other circumstances in which the product had been subjected to forces or loads beyond its design. This warranty does not cover paint damage or modifications to the product. Proof of purchase is required.

Warranty Repair

If for any reason it should be necessary to have warranty work done, return the product to a RockShox dealer. In the USA, dealers are required to call for a Return Authorization number (RA#) prior to returning product.

For more technical information, visit our website at www.rockshox.com. For toll-free technical support in the USA, call 1.800.677.7177. Customers in countries other than the USA should contact their local dealer or distributor.



Upper Tube (w/dust boot
Standrohr (mit Gabel-Boot)
Tubo superior con quitapolvos
Tube supérieur (avec gaine protectrice)
Tubo superiore della forcella (con parapolvere)
Bovenbuis (met stofbescherming)
Tubo superior (c/ capa contra poeira)
アッパーチューブ (ワグスタブート)

Steerer Tube
Gabelschaftrohr
Potencia (tubo de direccin)
Tube pivot
Stein di sterzo
Stuurbuis
Coluna de direo
ステアリング
チューブ

Preload Adjuster Knob
Einstellknopf fr Federvorspannung
Capenusa ajustadora de precarga
Bouton de rglage de la prcharge
Manopola di regolazione del precarico
Knop instelling voorbelasting
Botó de ajuste de precarregamento
プレロード 調整ノブ

Crown
Gabelkrone
Corona
TCE
Testa
Kroon
Coroa
クラウン

Brake Post
Montagesockel fr Bremse
Pasador de freno
Tige de frein
Supporto freno
Remhouder
Suporte do freio
ブレーキポスト

80 mm Travel - TT/C
80 mm Federweg - TT/C
80 mm de recorrido - TT/C
D'battement de 80 mm - TT/C
Escursione della forcella 80 mm - TT/C
80 mm bewegingsruimte - TT/C
Curso de 80 mm - TT/C
トラベル: 80 mm - TT/C

100 mm Travel - C
100 mm Federweg - C
100 mm de recorrido - C
D'battement de 100 mm - C
Escursione della forcella 100 mm - C
100 mm bewegingsruimte - C
Curso de 100 mm - C
トラベル: 100 mm - C

Shaft Bolts
Fhrungsschrauben
Boulons de tige
Pernos del eje
Bulloni fondo forceli
Asbouten
Parafusos do eixo
シャフト ボルト

Disc Brake Tabs
Scheibenbrems-Sockel
Lengijeta del freno de discos
Pattes de fixation des freins il disque
Linguette freno a disco
Lippen schijfremmen
Lingietas de freio a disco
ディスク ブレーキ タブ

NOTE: YOUR FORK'S APPEARANCE MAY VARY FROM THE ILLUSTRATIONS/PHOTOS IN THIS MANUAL.
FOR THE LATEST INFORMATION ABOUT YOUR FORK VISIT OUR WEBSITE AT WWW.ROCKSHOX.COM.

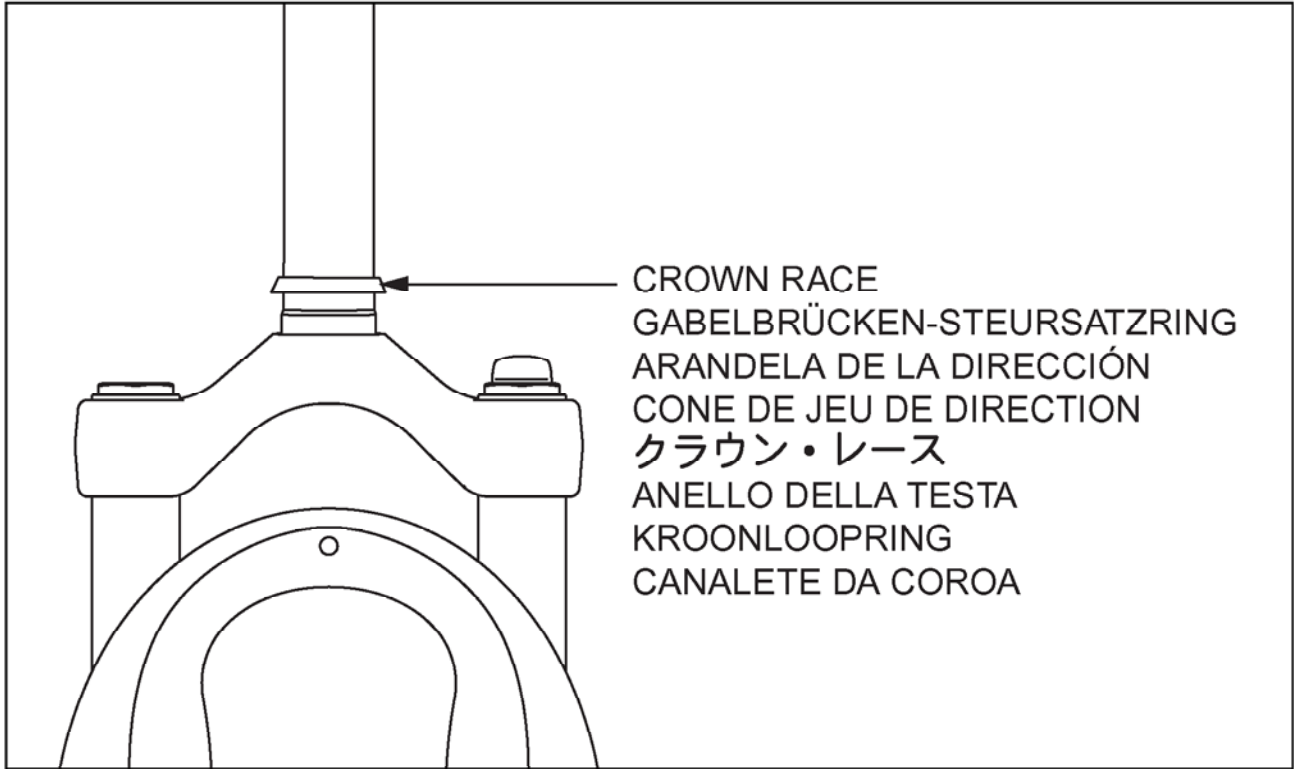

Fig. 1

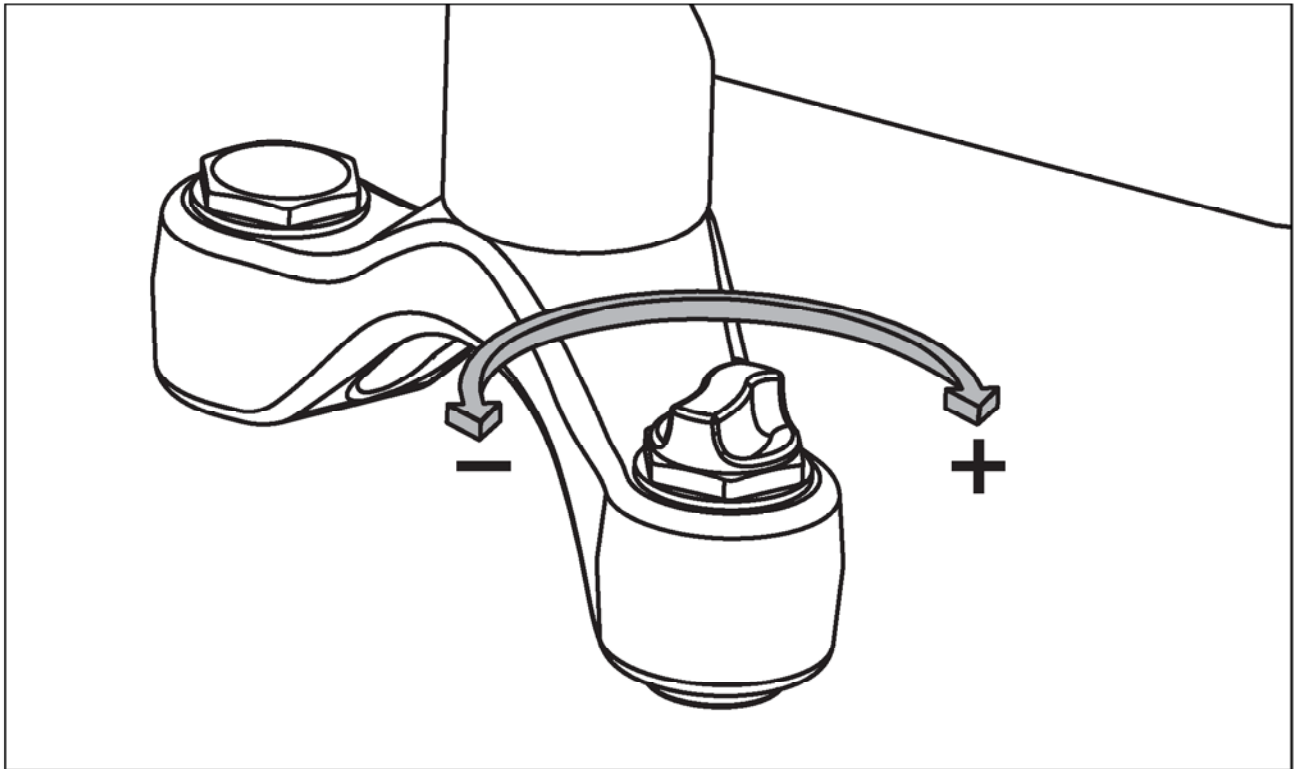

Fig. 2