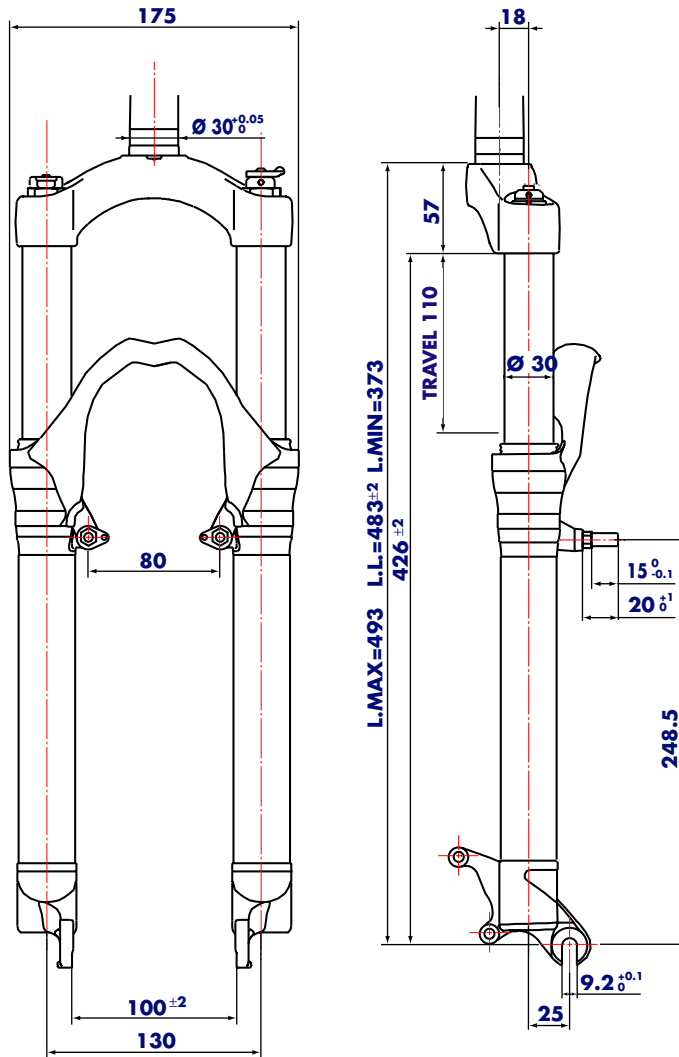


Z1  
Free  
Ride  
(110)



## GENERAL

- Special Freeride and Downhill fork whose legs are damped by a spiral springs and hydraulic cartridges system.
- Spring pre-load adjustment (in both legs) and rebound damping (left leg only) controlled via external top leg adjuster.
- The left leg is also damped by a hydraulic cartridge with a control knob limiting leg rebound (ECC).
- Stanchions fitted into lower Crown by cryofit technique. Full length bushings guarantee superior rigidity.
- Sliders and arch are an integral assembly for reduced weight and improved rigidity.
- Parts subjected to friction are cooled and lubricated by a specially formulated oil.

**Steer tube:** stainless steel or, on request, aluminum steer tube available for 1 1/8" diameter, threadless.

**Crown:** Forged and CNC-machined BAM\* aluminum alloy.

**Arch:** Cast BAM\* aluminium alloy, forged and machined by CNC machines.

**Stanchions:** anodized aluminum with variable butting.

**Sliders:** Forged and CNC-machined BAM\* aluminum alloy. Left slider equipped with disc brake adapter.

**Springs:** Constant pitch springs.

**Slider bushing:** Full length guide bushing composed of a copper base and impregnated with an anti-friction coating.

**Seals:** Computer designed oil seals guarantee the highest quality seals available.

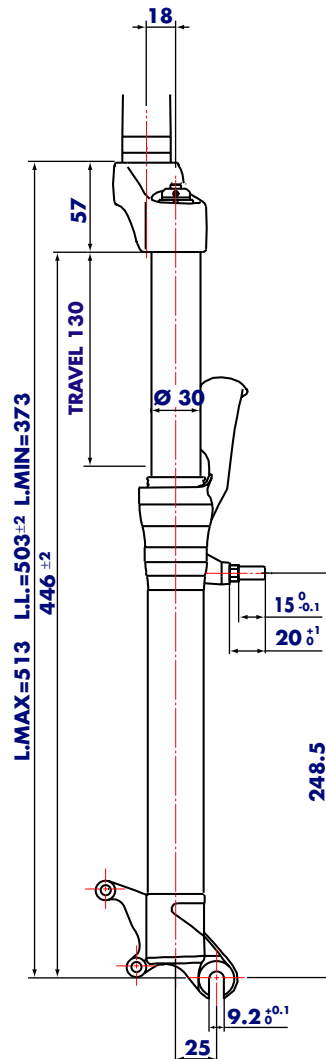
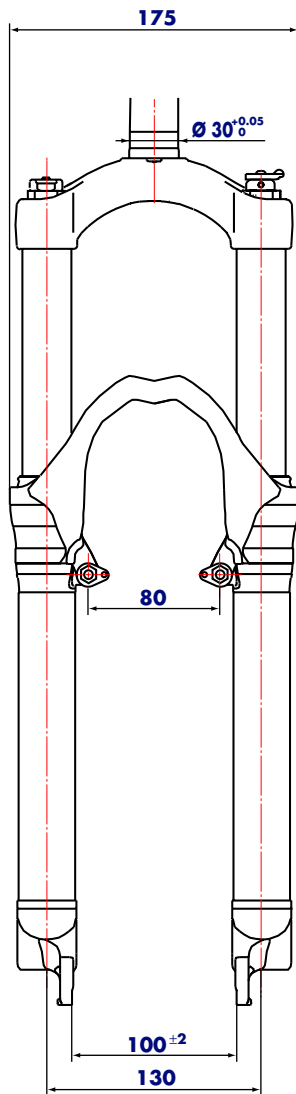
**Oil:** Specially formulated oil which eliminates foaming and viscosity breakdown while providing complete stiction-free performance.

**Fork leg oil:** 105 cc (each leg), type EBH 16 - SAE 7.5.

\* **BAM: Bomber Aerospace Material.**

Special alloy developed from aerospace material.

Z1  
Free  
Ride  
(130)



## GENERAL

- Special Freeride and Downhill fork whose legs are damped by a spiral springs and hydraulic cartridges system.
- Spring pre-load adjustment (in both legs) and rebound damping (left leg only) controlled via external top leg adjuster.
- The left leg is also damped by a hydraulic cartridge with a control knob limiting leg rebound (ECC).
- Stanchions fitted into lower Crown by cryofit technique. Full length bushings guarantee superior rigidity.
- Sliders and arch are an integral assembly for reduced weight and improved rigidity.
- Parts subjected to friction are cooled and lubricated by a specially formulated oil.

**Steer tube:** stainless steel or, on request, aluminum steer tube available for 1 1/8" diameter, threadless.

**Crown:** Forged and CNC-machined BAM\* aluminum alloy.

**Arch:** Cast BAM\* aluminium alloy, forged and machined by CNC machines.

**Stanchions:** anodized aluminum with variable butting.

**Sliders:** Forged and CNC-machined BAM\* aluminum alloy. Left slider equipped with disc brake adapter.

**Springs:** Constant pitch springs.

**Slider bushing:** Full length guide bushing composed of a copper base and impregnated with an anti-friction coating.

**Seals:** Computer designed oil seals guarantee the highest quality seals available.

**Oil:** Specially formulated oil which eliminates foaming and viscosity breakdown while providing complete stiction-free performance.

**Fork leg oil:** 105 cc (each leg), type EBH 16 - SAE 7.5.

\* **BAM: Bomber Aerospace Material.**

Special alloy developed from aerospace material.

# INSTRUCTIONS

## GENERAL RULES

1. Where specified, assemble and disassemble the shock absorption system using the **MARZOCCHI** special tools only, as shown in the table below.
2. On reassembling the suspension system, always use new seals.
3. Clean all metal parts with a special, preferably biodegradable solvent, such as trichloroethane or trichloroethylene.
4. Before reassembling, lubricate all parts in contact with each other using silicone fat spray.
5. Always grease the conic seal rings before reassembling.
6. Use wrenches with metric size only. Wrenches with inch size might damage the fastening devices even when their size is similar to that of the wrenches in metric size.

Z1  
Free  
Ride

## **FAILURES, CAUSES AND REMEDIES**

*This paragraph reports some failures that may occur when using the fork. It also indicates possible causes and suggests a remedy. Always refer to this table before doing any repair work.*

<b>FAILURES</b>	<b>CAUSES</b>	<b>REMEDIES</b>
<i>Oil leaking through the top of slider</i>	<i>1. Oil seal is worn out 2. Stanchion tube is scored 3. Excessive dirt on oil seal</i>	<i>1. Replace oil seal 2. Replace oil seal and stanchions and crown assembly 3. Clean the oil seal seat and replace oil seal</i>
<i>Oil leaking through the bottom of slider</i>	<i>O-ring on the cartridge seal nut damaged</i>	<i>Replace the O-ring</i>
<i>Fork has not been used for some time and is locked out</i>	<i>Oil seals and dust seals tend to stick to stanchion tube</i>	<i>Raise dust seal and lubricate stanchion tube, dust seal and oil seal with silicone grease</i>
<i>Fork rebounds too fast even though the adjuster is set to hardest damping position</i>	<i>Right leg cartridge is faulty</i>	<i>Replace hydraulic cartridge</i>
<i>Excessive play of stanchions in the sliders</i>	<i>Pilot bushings are worn</i>	<i>Replace pilot bushings</i>
<i>Fork does not react to adjustments</i>	<i>Legs inner parts are dirty</i>	<i>Carefully clean and replace oil</i>
<i>Fork does not react to rebound lock</i>	<i>LH fork cartridge faulty</i>	<i>Replace hydraulic cartridge</i>

**Z1**  
**Free**  
**Ride**

## RECOMMENDATIONS FOR MAINTENANCE

**MARZOCCHI** forks are based on advanced technology, supported by year-long experience in the field of professional mountain biking. In order to achieve best results, we recommend to check and clean the area below the dust seal and the stanchion tube after each use and lubricate with silicone oil.


In general, **MARZOCCHI** forks can offer top performance from the start. However, in some cases a short running-in period is required (5-10 hours) for inner adjustments. This running-in period will make fork life longer and ensure fork top performance over time.

**IMPORTANT:** change oil at least every 100 working hours.


**Polished** forks should be cleaned with bodywork **polish** at regular intervals in order to preserve their original finish.

## INSTALLATION


Installing the fork on a bicycle is a very delicate operation that should be carried out with extreme care. The installation should always be checked by one of our Technical Service Centers.

 **WARNING:** Steer tube/headset mounting and adjustment must be carried out in compliance with the headset manufacturer's instructions. Improper installation may jeopardize the safety of the rider.

To replace it, contact one of our Technical Service Centers with the required tools.

 **WARNING:** In case of improper installation of the steer tube into the crown, the rider might lose control of his/her bicycle, thus jeopardizing his/her safety.

## DISC BRAKE SYSTEM ASSEMBLY

 **WARNING:** If a disc brake system is installed, it is absolutely forbidden to loosen and remove original brake supports fixing pins. In fact, apart from retaining Cantilever or V-brake levers, they also play an important role in securing slider bottom to slider-arch monolith. If needed, replace these pins with screws (part no. **532979QF**) available as spare parts. Tighten the above screws to 10 Nm.

**IMPORTANT:** screw and pin threading is treated to ensure hydraulic seal. Never reuse screws and pins which have been removed.

Assembling the brake caliper onto the slider is a very delicate operation that should be carried out with extreme care. Improper assembly might overstress the caliper supports which might break. When installing the disc brake system, be sure to properly follow the instructions given by the manufacturer.

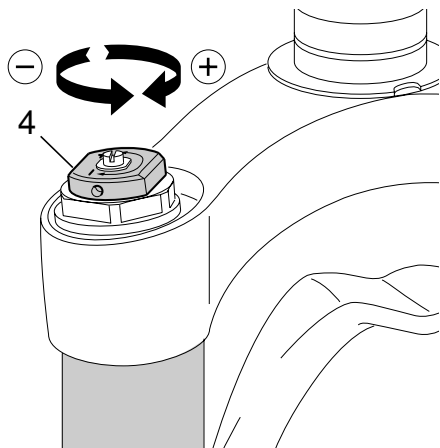
Z1  
Free  
Ride

## ADJUSTMENTS

### SPRING PRELOAD

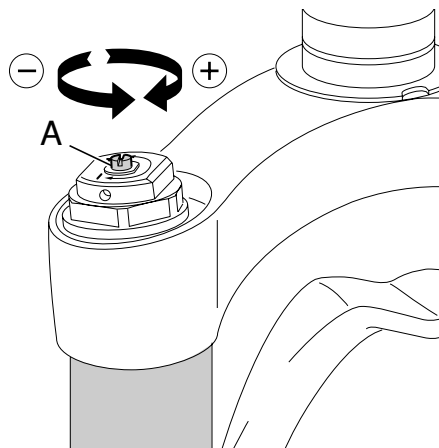
The spring preload determines COMPRESION damping and can be adjusted by turning the knob (4) on top of the fork legs. From the factory the fork is set at minimum preload, i.e. the adjustment knob completely unscrewed counterclockwise. However, the springs are slightly preloaded to help counteract static loads. By turning the adjustment knob clockwise, the preload is increased up to the maximum value equal to 15 mm's of spring preload. This adjustment is essential in order to have the right fork response for the rider's weight and riding style.

Z1  
Free  
Ride



### REBOUND ADJUSTMENT (only right leg)

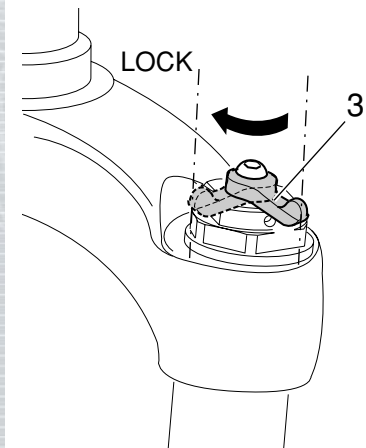
The right fork leg is equipped with an adjuster screw (A) for REBOUND damping. Turning this adjuster clockwise into the cartridge rod, changes the hydraulic setting of the inner valves. In short, the amount of adjustment applied on the piston in the fluid determines the rate of damping. To adjust, always start from the minimum damping setting, i.e. unscrew completely counterclockwise. About 8 turns - abt. 4 mm of the adjustment - are possible.



### REBOUND LIMITER (only left leg)

In case of hard uphill path, fork leg rebound can be locked for improved behavior. Position the knob (3) on l.h. fork leg top to "LOCK" to lock rebound limit in this position; this also allows to decrease fork leg height for optimal attitude uphill, thus supporting suspension compression operation. Reposition the knob to its original position so that the fork will rebound and restart to work as before.

**WARNING:** do not position to "LOCK" when riding downhill as available travel might not be enough, thus jeopardizing rider's safety



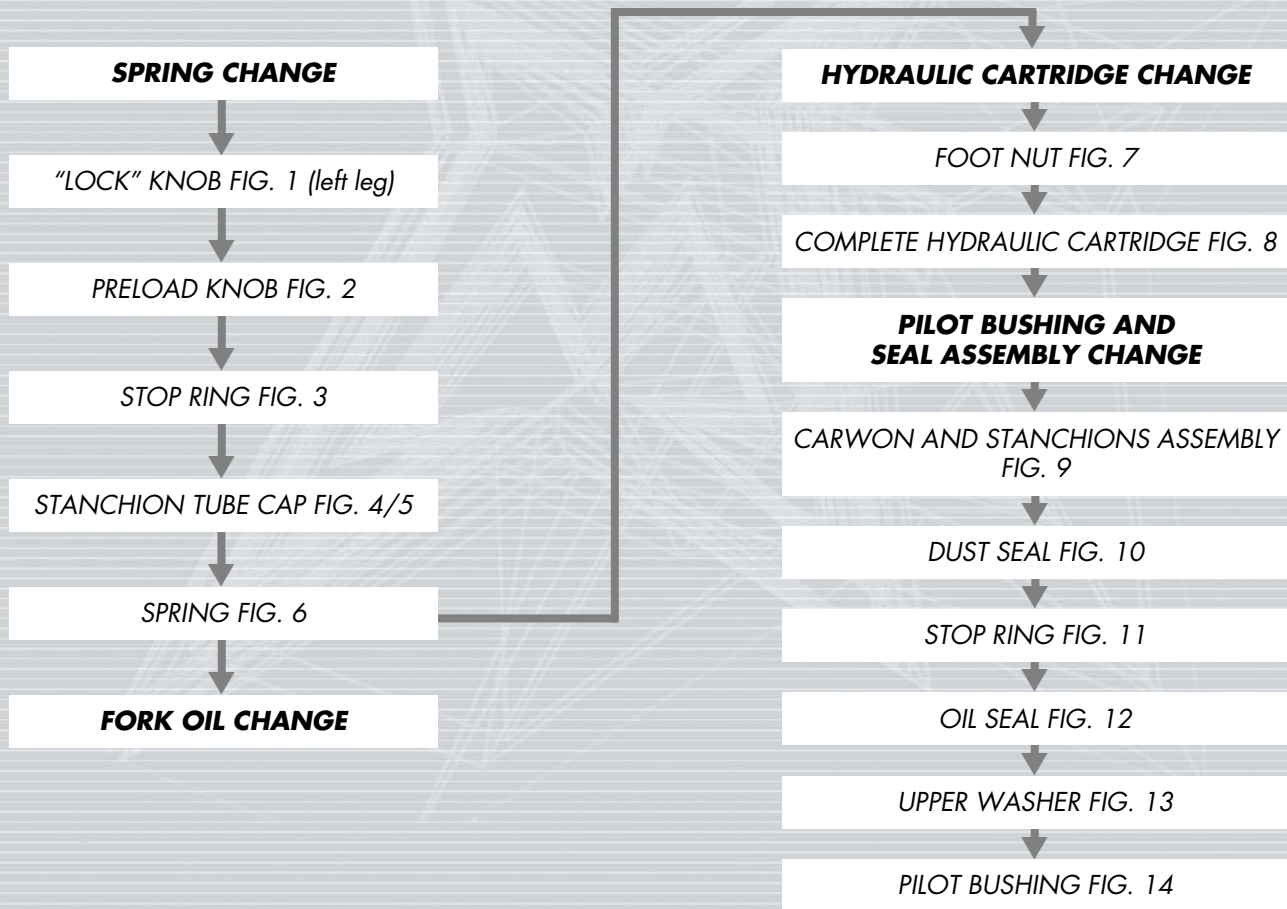
# DISASSEMBLY

## GENERAL

- The reference numbers given in this section relate to the components shown in the forks exploded view.
- Before starting any operation, please read the diagram below. It shows the quickest procedure and the exact sequence in which it should be disassembled. Locate the part you need to remove in the diagram, then look at the arrows to determine which other parts you will need to remove first.

## DISASSEMBLY DIAGRAM

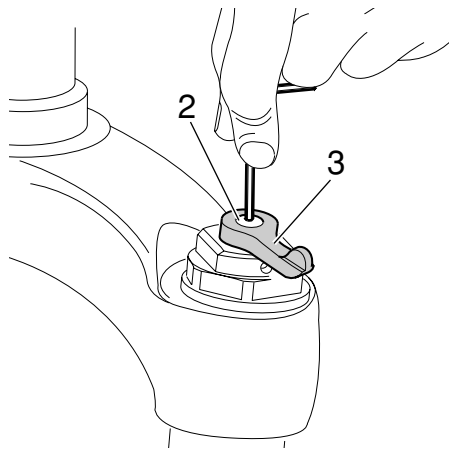
Z1  
Free  
Ride



## **SPRING CHANGE**

### **FIG. 1 (only left leg)**

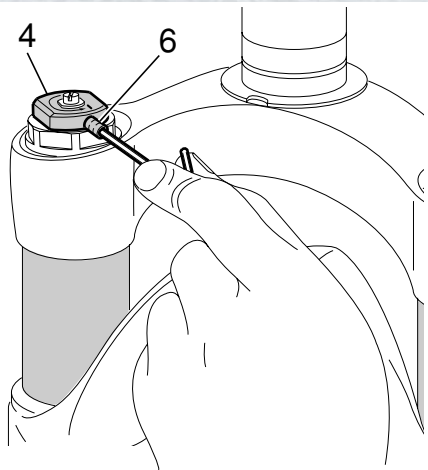
Loosen screw **(2)** and remove rebound limiting knob **(3)**.



### **FIG. 2**

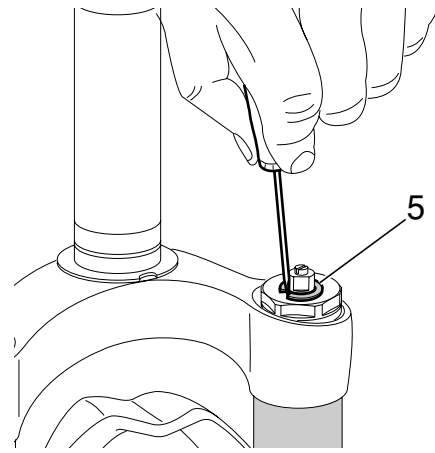
Set knob **(4)** of both legs to minimum preload.

Loosen dowels **(6)** fastening the preload knobs by means of a 1.5 mm Allen wrench. Remove the knobs from the caps.



### **FIG. 3**

Remove preload knob support stop rings **(5)** from the top of the cap with a small screwdriver.



**Z1**  
**Free**  
**Ride**

**FIG. 4**

Unscrew the caps (7) with a 21 mm socket wrench.  
Remove the caps complete with O-ring (8) from the stanchions.

**FIG. 5**

Lock the check nuts (38) and remove the caps (7) from hydraulic cartridges end (12) and (28).

**FIG. 6**

Push the stanchions into the sliders.  
Remove the lower washer (10) and the spring (11) in both fork legs.

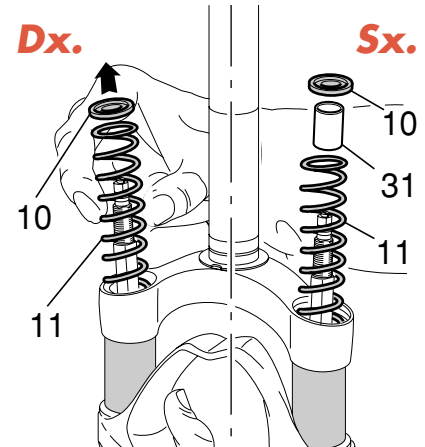
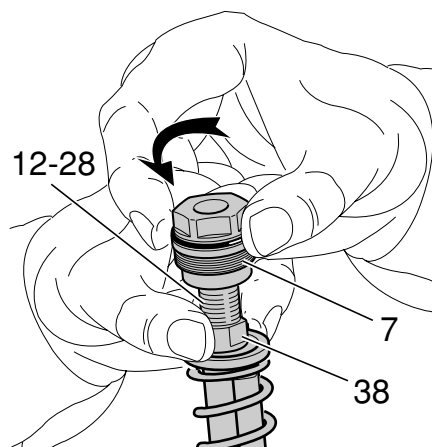
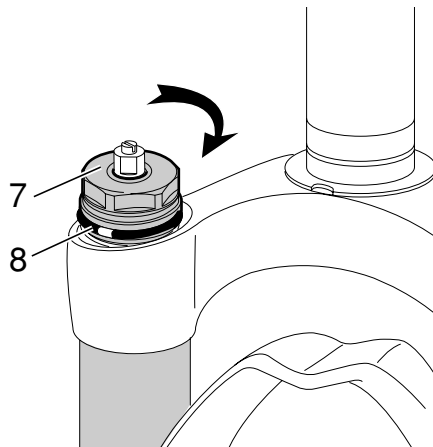
**(only for travel of 110)**

In LH fork leg, between lower washer (10) and spring (11) there is a preload tube (31).

Let all the oil drain into the fork leg. By following this procedure, there is no need to check the oil level.

Make all necessary changes.

Z1  
Free  
Ride



## HYDRAULIC CARTRIDGE CHANGE

### FIG. 7

Drain all oil from the fork legs.

**⚠ WARNING:** Remember to always recycle any used oil.

To change the fork leg oil follow the procedure as described in section "REASSEMBLY" from Fig. 23 to Fig. 29.

Turn the fork leg upside-down and unscrew the foot nut (20) complete with O-ring (19) by the use of a 15 mm socket wrench.

Z1  
Free  
Ride

### FIG. 8

Remove hydraulic cartridges (12) and (28) and keep the rebound spring.

**IMPORTANT:** cartridges fitted to forks with a **travel of 130** feature a rebound spring (26) that is the same fitted in both fork legs.

Rebound springs in forks with a **travel of 110** are different: rebound spring (26) is in the LH fork leg, while rebound spring (34) is in the RH fork leg.

Remove the bottom washers (23, see exploded view) from inside the stanchions. Replace the whole hydraulic cartridges.

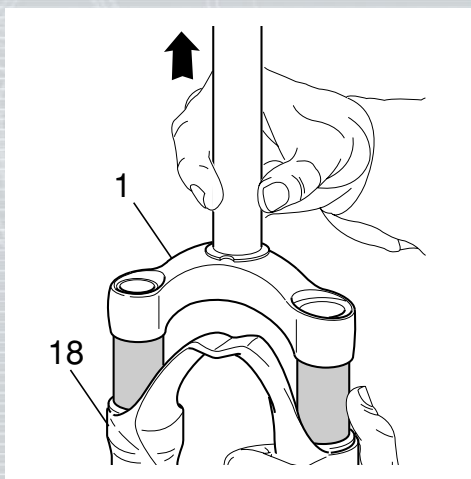
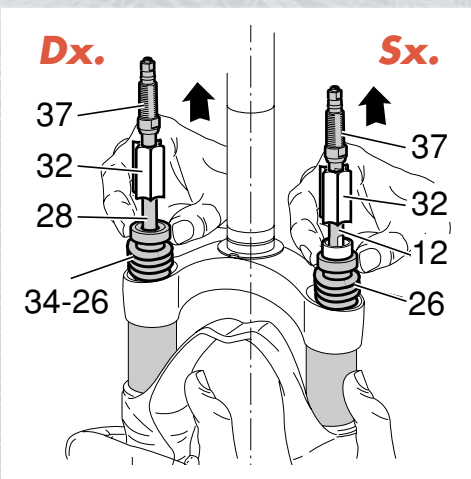
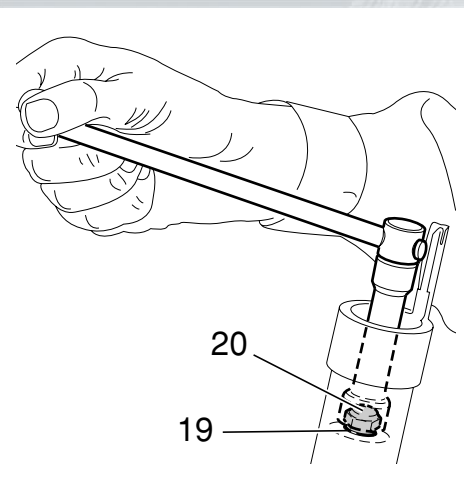
**NOTE:** the hydraulic cartridge is supplied with gaskets and lock nut (38). This model features both support (37) for the preload knob and spring guide (32).

These parts can be also ordered separately (see exploded view).

## PILOT BUSHING AND SEAL ASSEMBLY CHANGE

### FIG. 9

Pull the crown and stanchions assembly (1) completely out of the sliders (18).



**FIG. 10**

Use a small screwdriver and remove the dust seal (13) from the top of the slider.

**FIG. 11**

Remove the stop ring (14) from the slider by placing the screwdriver bit in one of the three openings on the stop ring and carefully lifting the ring out of place.

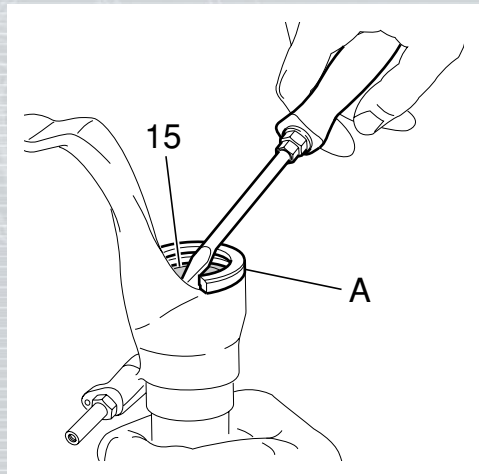
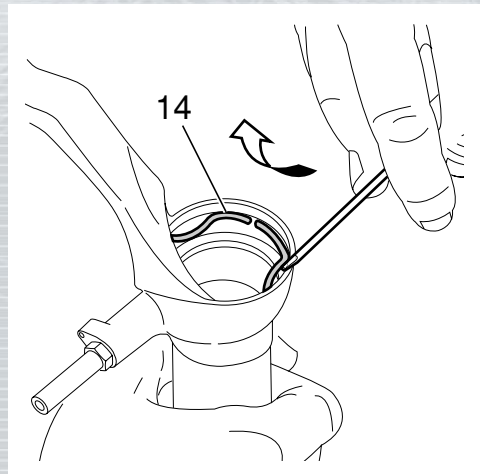
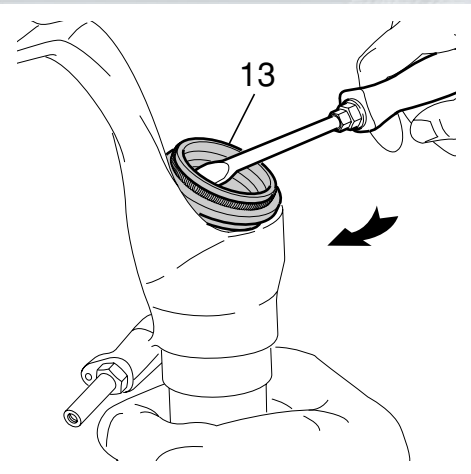
**IMPORTANT:** when removing the stop ring, make sure not to damage its seat.

**FIG. 12**

Fit the slider protector (A) onto the slider and remove the oil seal (15) with the help of a large slot screwdriver.

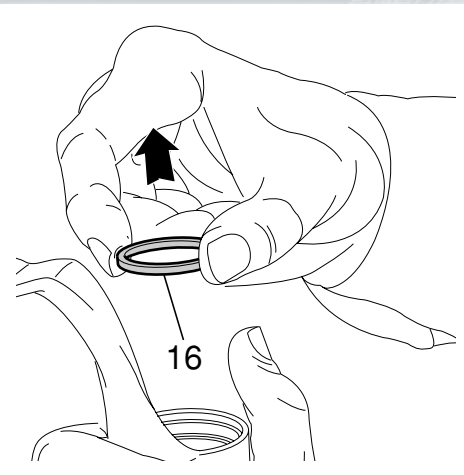
**IMPORTANT:** when removing the oil seal, make sure not to damage its seat. Once removed the oil seals should not be used again.

Z1  
Free  
Ride



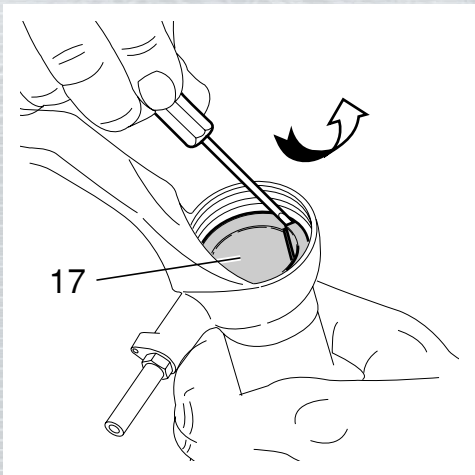
**FIG. 13**

Remove the upper washer (16) from the slider.



**FIG. 14**

Fit the bit of a small screwdriver into the upper edge slot of the pilot bushing (17) and lift gently. Pull the bushing out of the slider and make all necessary changes.



Z1  
Free  
Ride

## REASSEMBLY

**CAUTION:** before reassembling, clean all metal parts carefully with inflammable and biodegradable solvent and dry them with compressed air.

### PILOT BUSHING AND SEAL ASSEMBLY

#### FIG. 15

Check that no dirt or debris is between slider and bushing. Insert the pilot bushing (17) into place so that it adheres to the slider.

#### FIG. 16

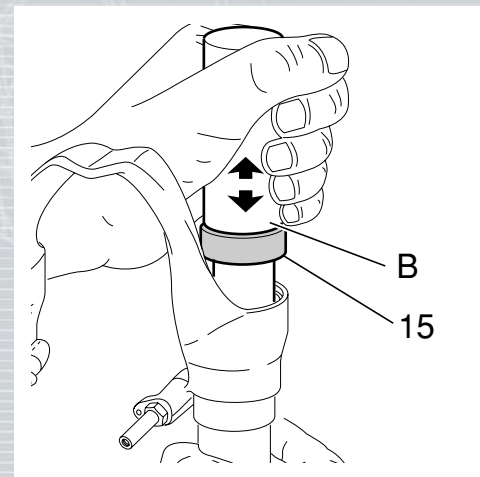
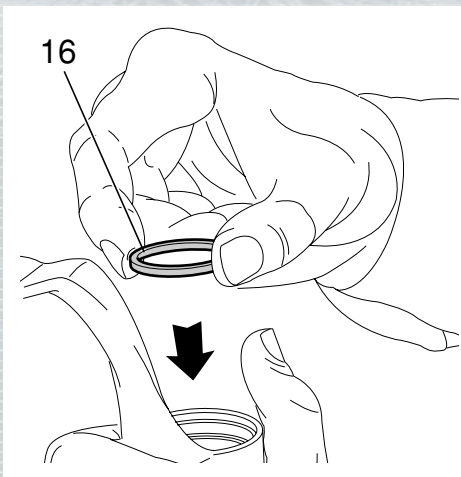
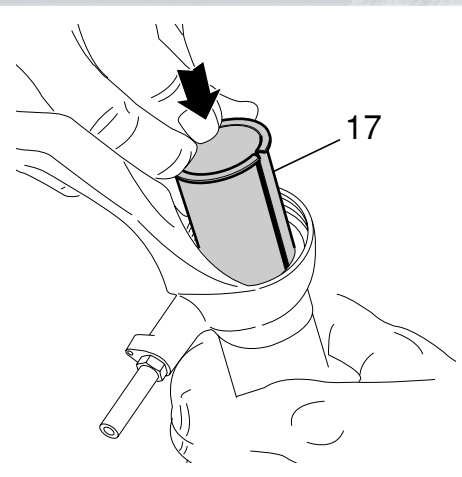
Fit the upper washer (16) into the slider so that it touches the pilot bushing.

#### FIG. 17

Lubricate the oil seal (15) and place it onto the seal press (B) with the hollow side toward the slider.

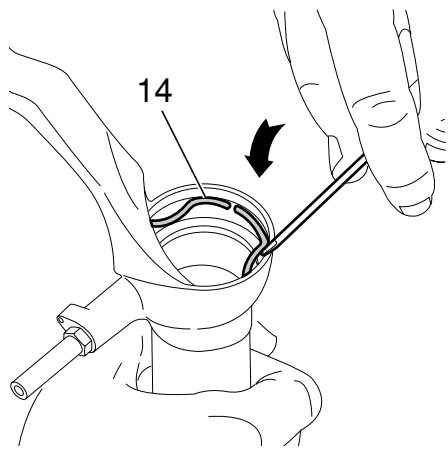
Press the oil seal into place until it touches the lower washer by using the above seal press.

Z1  
Free  
Ride

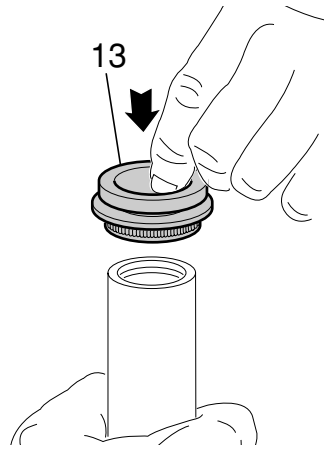


**FIG. 18**

Insert the stop ring (14) making sure it is properly seated into place.  
Use buffer (B) to properly seat the ring into the slider.

**FIG. 19**

Lubricate the dust seals (13) and fit them into the stanchions from the spring end.

**CROWN AND STANCHIONS ASSEMBLY****FIG. 20**

Fit the stanchions and crown assembly (1) with the dust seals in place gently into the sliders seals.

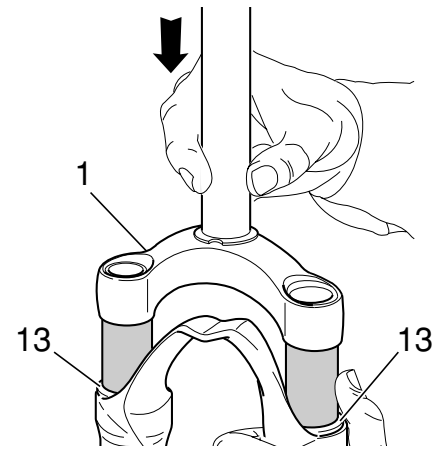
**WARNING:** to avoid any damages to sealing surfaces, keep the stanchions duly lubricated and squared into the sliders.

Check to see that the stanchion tube slides unrestricted by cycling the fork up and down several times.

The tube should slide freely inside the seal assembly without any side play.

In the event it is too hard or too soft, repeat the previous steps described above and check components to ensure they are not damaged.

Seat the dust seals (13) on top of the sliders.



Z1  
Free  
Ride

## HYDRAULIC CARTRIDGE RE-FITTING

### FIG. 21

Push the stanchions up to slider bottom.  
If removed, insert the bottom washers (23, see exploded view) in the stanchion.  
Slide in the cartridges fitted to forks with **travel of 130**, the rebound spring (26).  
Slide in the LH cartridge fitted to forks with **travel of 110**, the rebound spring (26) and the rebound spring (34) in the RH cartridge;  
Push the hydraulic cartridges (12) and (28), complete with seals and retaining parts, fully inside the stanchions.

### FIG. 22

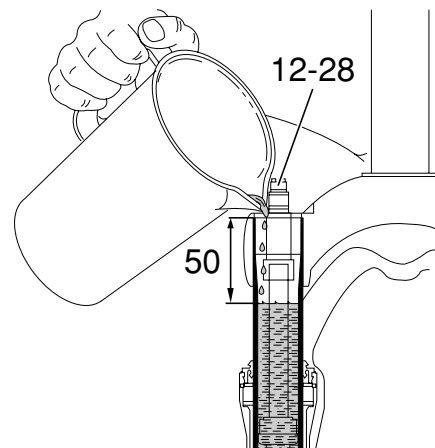
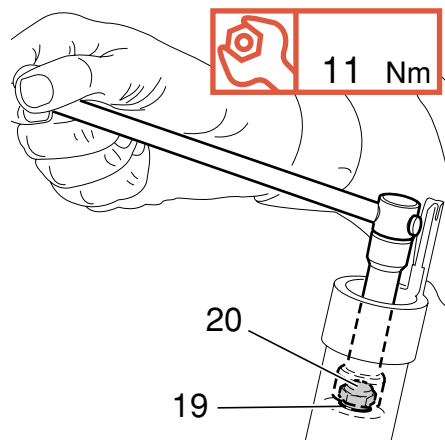
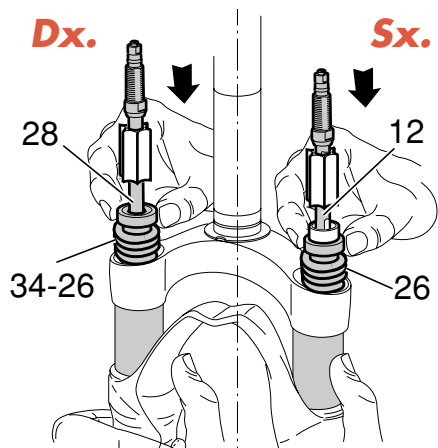
Grease the O-ring (19) on the foot nut (20) and screw the nut on the threaded end of the hydraulic cartridges.  
Tighten to 11 Nm.  
Check to verify that the stanchions slide properly through the stroke by pumping them up and down several times.

## HOW TO FILL WITH OIL

### FIG. 23

Pour the oil little by little when the stanchions are fully down and then pump with the cartridges (12) and (28) rod so as to have a better filling.  
Cartridge is full when no air is detected when pumping, in the completely closed position.  
Check that oil level is 50 mm from the top of the stanchion tube in both fork legs.

Z1  
Free  
Ride



## SPRING AND CAP

### FIG. 24

Fit the springs (11) into the stanchions. Slide the preload tube (31) in the LH fork leg fitted to forks with a **travel of 110**, then fit the washers (10). Move the preload adjuster (9, see exploded view), in the cap, to the minimum preload position.

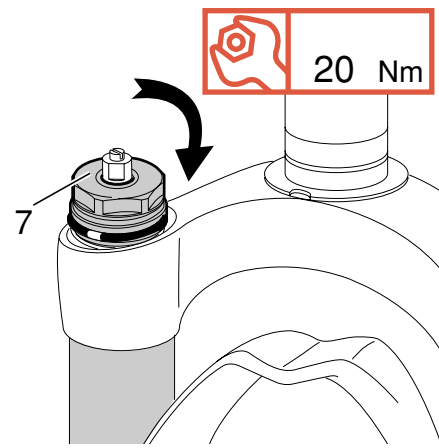
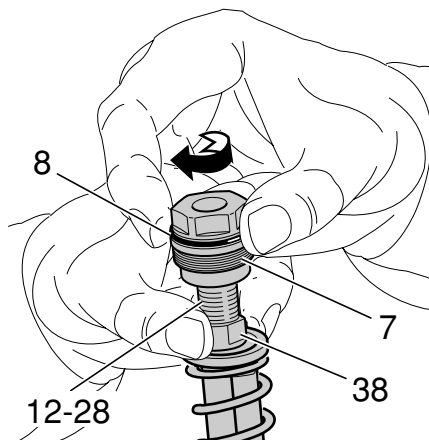
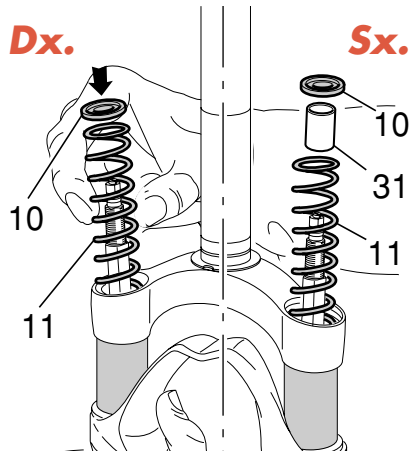
### FIG. 25

Lubricate the O-ring (27, see exploded view) on the top of the preload knob support and the O-ring (8) on the cap (7). Screw the cap (7) complete with pusher (9) onto the cartridges (12-28) rod. Screw cap all the way in. Tighten check nut (38) against cap (7).

### FIG. 26

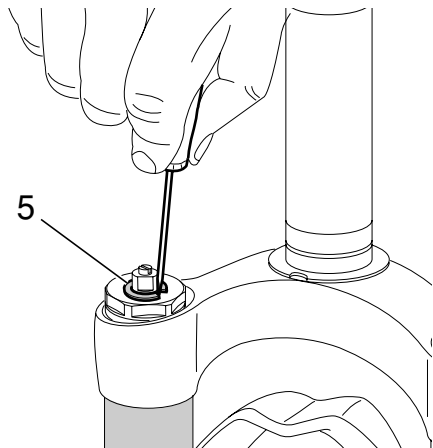
Lift the stanchions and start the caps (7) onto the threads by hand. Tighten the caps to 20 Nm.

Z1  
Free  
Ride



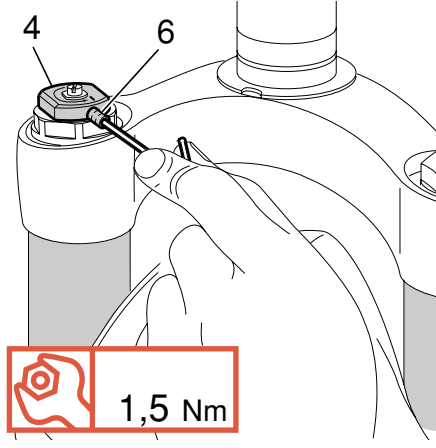
**FIG. 27**

Fit the stop ring (5) of the preload knob support and make sure it is properly seated into place.



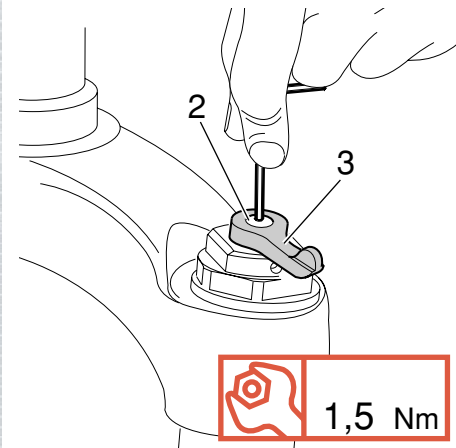
**FIG. 28**

Fit the preload knob (4) and secure it on the support by tightening the grub screw (6) to 1.5 Nm.



**FIG. 29 (left leg only)**

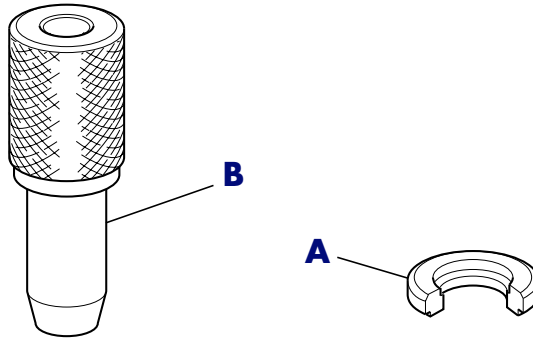
Set rebound limiting knob (3) on RH leg adjuster and tighten screw (2) to the torque of 1,5 Nm.



Z1  
Free  
Ride

## SPECIFIC TOOLS

Ref.	Item.	Description and use
<b>A</b>	R 5089 AB	Slider protector: to remove the oil seal from the slider
<b>B</b>	R 5090	Oil seal press: to press oil seal into the slider



Z1  
Free  
Ride