

Z3 QR20 (110)

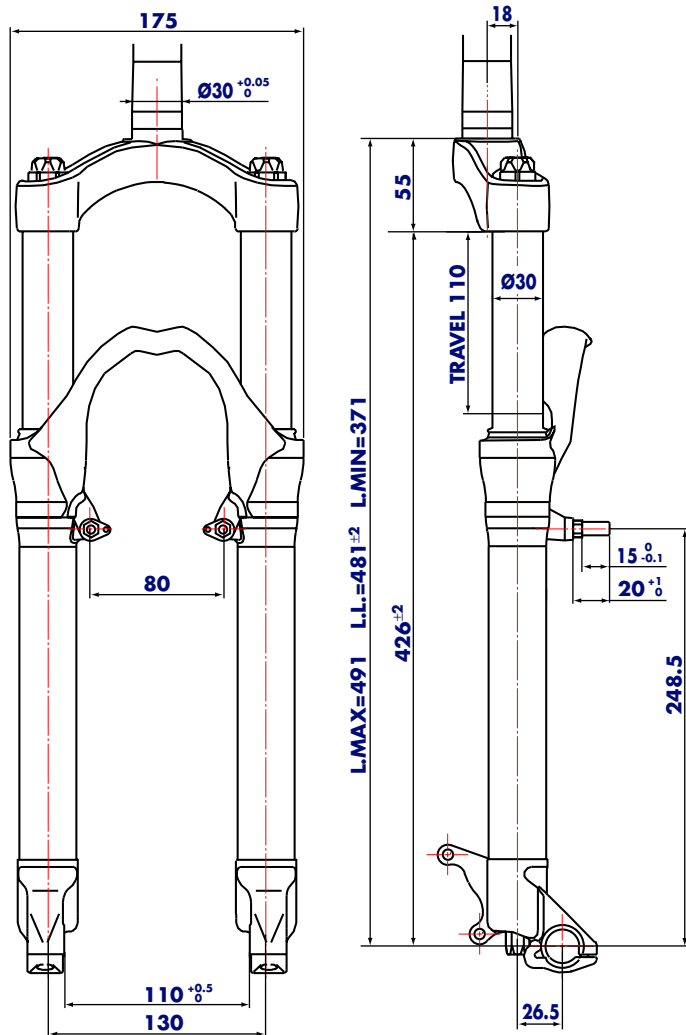

GENERAL

- The fork is sprung by a mechanical coil system and uses hydraulic rebound damping.
- Spring pre-load adjustment controlled via external top mount adjuster, rebound damping adjustment controlled by bottom adjuster of right fork leg.
- Stanchions fitted into lower Crown by cryofit technique. Full length bushings guarantee superior rigidity.
- Sliders and arch are an integral assembly for reduced weight and improved rigidity.
- Parts subjected to friction are cooled and lubricated by a specially formulated oil.
- QR20 wheel shaft retaining system for special hubs (110-mm stop) and wheel shafts with 20-mm diameter.

Steer tube: stainless steel or, on request, EASTON aluminum steer tube available for 1 1/8" diameter, threadless.

Crown: Forged and CNC-machined BAM* aluminum alloy.

Arch: Cast magnesium alloy.

Stanchions: anodized EASTON aluminum with variable butting.

Springs: Constant pitch springs.

Sliders: Forged and CNC-machined BAM* aluminum alloy. Left slider comes with supports for disc brake caliper.

Slider bushing: Full length guide bushings composed of a copper base and impregnated with an anti-friction coating.

Seals: Computer designed oil seals guarantee the highest quality seals available.

Oil: Specially formulated oil which eliminates foaming and viscosity breakdown while providing complete stiction-free performance.

Fork leg oil: 85 cc (each leg), type EBH 16 - SAE 7.5.

* **BAM: Bomber Aerospace Material.**

Special alloy developed from aerospace material.

Z3 QR20 (130)

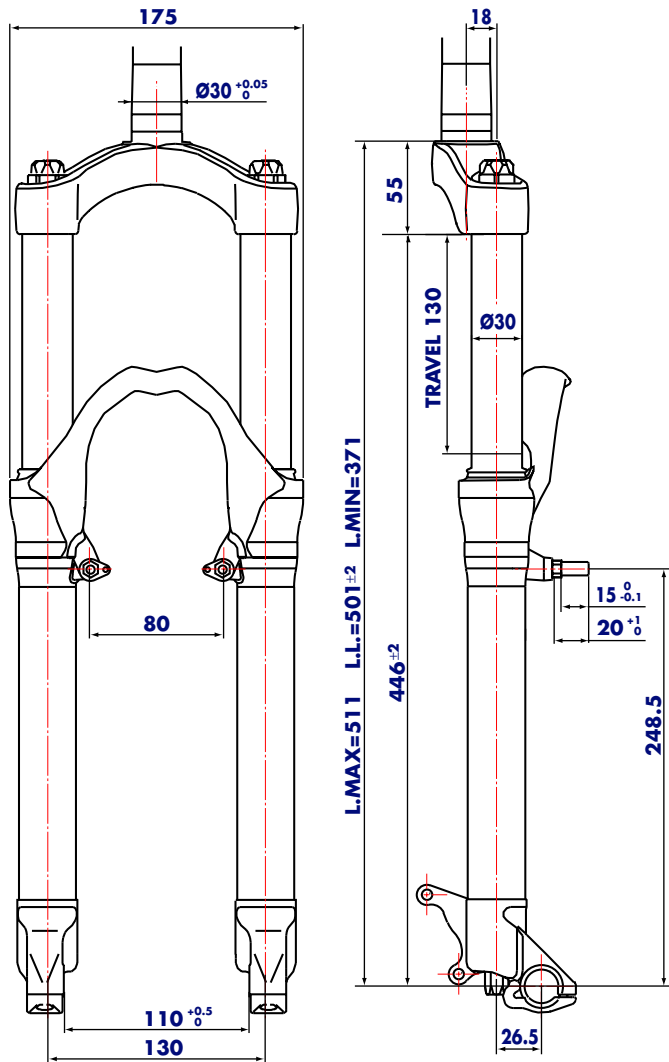

GENERAL

- The fork is sprung by a mechanical coil system and uses hydraulic rebound damping.
- Spring pre-load adjustment controlled via external top mount adjuster, rebound damping adjustment controlled by bottom adjuster of right fork leg.
- Stanchions fitted into lower Crown by cryofit technique. Full length bushings guarantee superior rigidity.
- Sliders and arch are an integral assembly for reduced weight and improved rigidity.
- Parts subjected to friction are cooled and lubricated by a specially formulated oil.
- QR20 wheel shaft retaining system for special hubs (1 10-mm stop) and wheel shafts with 20-mm diameter.

Steer tube: stainless steel or, on request, EASTON aluminum steer tube available for 1 1/8" diameter, threadless.

Crown: Forged and CNC-machined BAM* aluminum alloy.

Arch: Cast magnesium alloy.

Stanchions: anodized EASTON aluminum with variable butting.

Springs: Constant pitch springs.

Sliders: Forged and CNC-machined BAM* aluminum alloy. Left slider comes with supports for disc brake caliper.

Slider bushing: Full length guide bushings composed of a copper base and impregnated with an anti-friction coating.

Seals: Computer designed oil seals guarantee the highest quality seals available.

Oil: Specially formulated oil which eliminates foaming and viscosity breakdown while providing complete stiction-free performance.

Fork leg oil: 90 cc (each leg), type EBH 16 - SAE 7.5.

* **BAM: Bomber Aerospace Material.**

Special alloy developed from aerospace material.

Z3 QR20 (100)

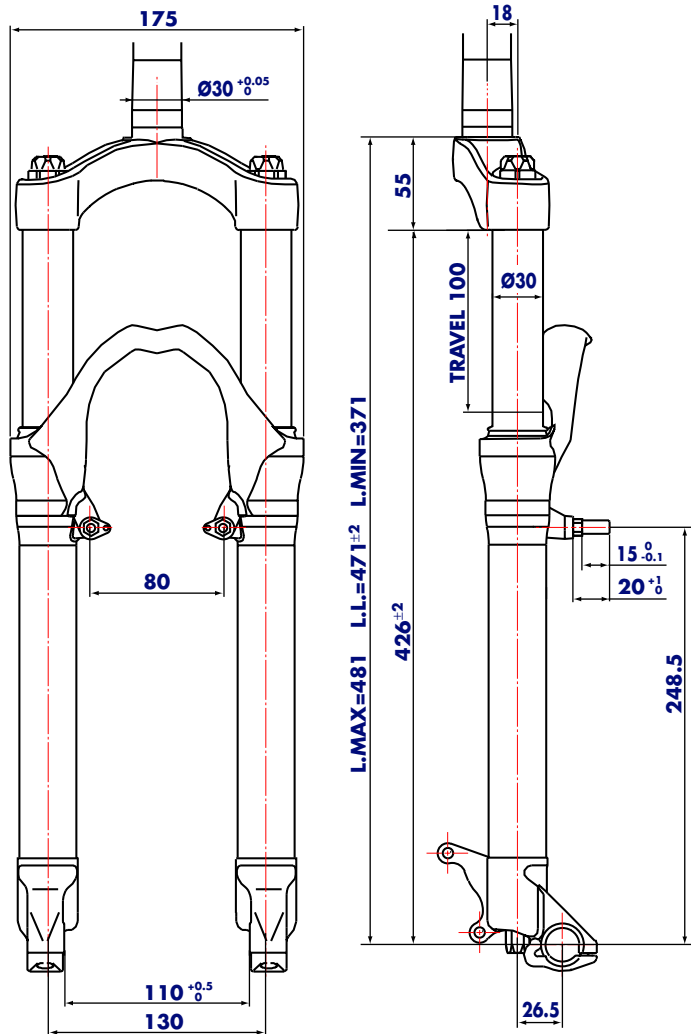

GENERAL

- The fork is sprung by a mechanical coil system and uses hydraulic rebound damping.
- Spring pre-load adjustment controlled via external top mount adjuster, rebound damping adjustment controlled by bottom adjuster of right fork leg.
- Stanchions fitted into lower Crown by cryofit technique. Full length bushings guarantee superior rigidity.
- Sliders and arch are an integral assembly for reduced weight and improved rigidity.
- Parts subjected to friction are cooled and lubricated by a specially formulated oil.
- QR20 wheel shaft retaining system for special hubs (1 10-mm stop) and wheel shafts with 20-mm diameter.

Steer tube: stainless steel or, on request, EASTON aluminum steer tube available for 1 1/8" diameter, threadless.

Crown: Forged and CNC-machined BAM* aluminum alloy.

Arch: Cast magnesium alloy.

Stanchions: anodized EASTON aluminum with variable butting.

Springs: Constant pitch springs.

Sliders: Forged and CNC-machined BAM* aluminum alloy. Left slider comes with supports for disc brake caliper.

Slider bushing: Full length guide bushings composed of a copper base and impregnated with an anti-friction coating.

Seals: Computer designed oil seals guarantee the highest quality seals available.

Oil: Specially formulated oil which eliminates foaming and viscosity breakdown while providing complete stiction-free performance.

Fork leg oil: 85 cc (each leg), type EBH 16 - SAE 7.5.

* **BAM: Bomber Aerospace Material.**

Special alloy developed from aerospace material.

INSTRUCTIONS

GENERAL RULES

1. Where specified, assemble and disassemble the shock absorption system using the **MARZOCCHI** special tools only.
2. On reassembling the suspension system, always use new seals.
3. Clean all metal parts with a special, preferably biodegradable solvent, such as trichloroethane or trichloroethylene.
4. Before reassembling, lubricate all parts in contact with each other using silicone fat spray or a specific oil for seals.
5. Always grease the lip seal rings before reassembling.
6. Use wrenches with metric size only. Wrenches with inch size might damage the fastening devices even when their size is similar to that of the wrenches in metric size.

Z3

QR20

FAILURES, CAUSES AND REMEDIES

This paragraph reports some failures that may occur when using the fork. It also indicates possible causes and suggests a remedy. Always refer to this table before doing any repair work.

FAILURES

CAUSES

REMEDIES

Oil leaking though the top of slider

- 1. Oil seal is worn out*
- 2. Stanchion tube is scored*
- 3. Excessive dirt on oil seal*

- 1. Replace oil seal*
- 2. Replace crown/stanchions assembly, oil seals and dust seals*
- 3. Clean the oil seal seat and replace oil seal*

Oil leaking through the bottom of slider

O-rings at pumping element bottom and adjusting rod damaged.

Replace the O-rings

Fork has not been used for some time and is locked out

Oil seals and dust seals tend to stick to stanchions

Raise dust seal and lubricate stanchion tube, dust seal and oil seal

Excessive play of stanchions in the sliders

Pilot bushings are worn

Replace pilot bushings

Adjuster position does not affect fork operation

- 1. Dirt inside legs*
- 2. O-ring into pumping element damaged.*

- 1. Clean carefully and change oil*
- 2. Replace O-ring.*

Z3

QR20

RECOMMENDATIONS FOR MAINTENANCE

MARZOCCHI forks are based on advanced technology, supported by year-long experience in the field of professional mountain biking. In order to achieve best results, we recommend to check and clean the area below the dust seal and the stanchion tube after each use and lubricate with silicone oil.

In general, **MARZOCCHI** forks can offer top performance from the start. However, in some cases a short running-in period is required (5-10 hours) for inner adjustments. This running-in period will make fork life longer and ensure fork top performance over time.

IMPORTANT: change oil at least every 100 working hours.

Polished forks should be cleaned with bodywork **polish** at regular intervals in order to preserve their original finish.

Z3

QR20

INSTALLATION

Installing the fork on a bicycle is a very delicate operation that should be carried out with extreme care. The installation should always be checked by one of our Technical Service Centers.

⚠ WARNING: Steer tube/headset mounting and adjustment must be carried out in compliance with the headset manufacturer's instructions. Improper installation may jeopardize the safety of the rider.

To replace it, contact one of our Technical Service Centers with the required tools.

⚠ WARNING: In case of improper installation of the steer tube into the crown, the rider might lose control of his/her bicycle, thus jeopardizing his/her safety.

FRONT WHEEL ASSEMBLY

IMPORTANT: fixing the front wheel properly as specified in the instructions given below is essential for the proper operation of this fork and all related devices, and therefore for safe riding. You are advised to follow these instructions closely.

Slacken the lock nut of the quick release lever so the hub will fit between the fork sliders.

Make sure the quick release bushings **(A)** are centered to the recesses in the sliders. Lock the quick release lever **(B)** and make sure the bushings **(A)** are properly seated in the sliders.

Fit bolt end **(C)** in suitable slider groove and tighten the screw **(D)** to specified torque.

⚠ WARNING: These sliders are specifically designed to fit this type of hub. Do not use any hub design other than that specified here, as this would not ensure proper fastening of the wheel and may lead to breakdown of the assembly components.

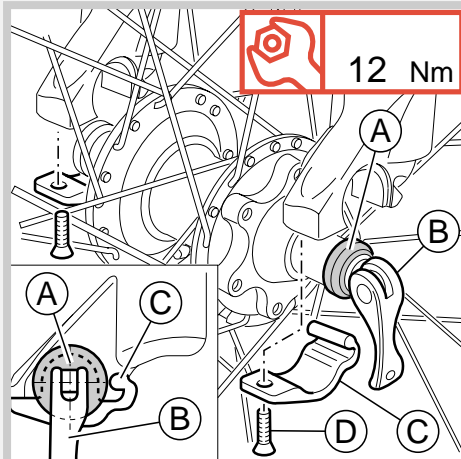

DISC BRAKE SYSTEM ASSEMBLY

⚠ WARNING: If a disc brake system is installed, it is absolutely forbidden to loosen and remove original brake supports fixing pins. In fact, apart from retaining Cantilever or V-brake levers, they also play an important role in securing slider bottom to slider-arch monolith. If needed, replace these pins with screws (part no. **532979QF**) available as spare parts.

Tighten the above screws to 15 Nm.

IMPORTANT: screw and pin threading is treated to ensure hydraulic seal. Never reuse screws and pins which have been removed.

Assembling the brake caliper onto the slider is a very delicate operation that should be carried out with extreme care. Improper assembly might overstress the caliper supports which might break. When installing the disc brake system, be sure to properly follow the instructions given by the manufacturer.

ADJUSTMENT

SPRING PRELOAD

Spring preload determines COMPRESSSION damping and is adjusted by turning the adjustment knob **(3)** on the top of the fork legs. From the factory the fork is set at minimum preload, i.e. the adjustment knob completely unscrewed counterclockwise. However, springs are slightly preloaded to counteract static loads. By turning the adjustment knob clockwise, the preload is increased up to the maximum value equal to 15 mm spring preload. This adjustment is essential in order to have the right fork response for the rider's weight and riding style.

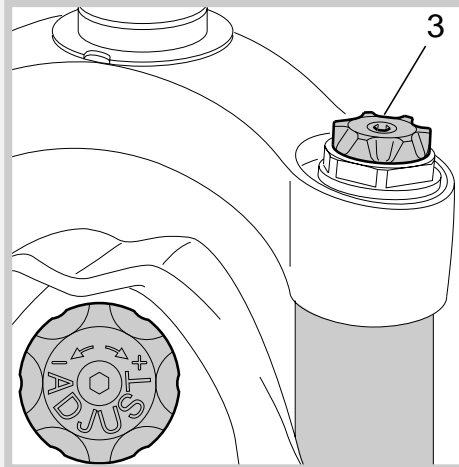

REBOUND ADJUSTMENT

Right slider bottom is equipped with an adjuster screw **(C)** for REBOUND damping.

To adjust, always start from the minimum damping setting, i.e. with the screw fully turned counterclockwise. Each adjusting position can be identified by a click.

IMPORTANT: do not force the adjuster knob **(C)** over its limit.

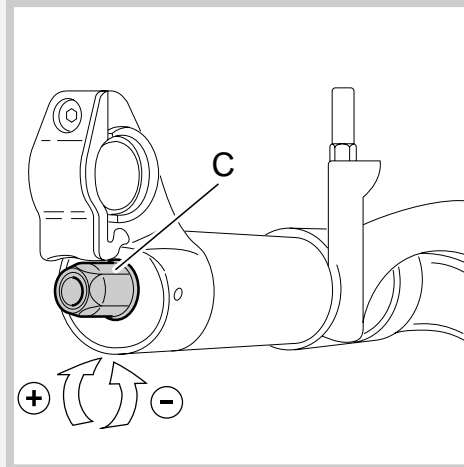

Z3

QR20

DISASSEMBLY

GENERAL

- The reference numbers given in this section relate to the components shown in the fork exploded view.
- Before starting any operation, please read the diagram below. It shows the quickest procedure and the exact disassembling sequence. Locate the part you need to remove in the diagram, then look at the arrows to determine which other parts you need to remove first.

DISASSEMBLY DIAGRAM

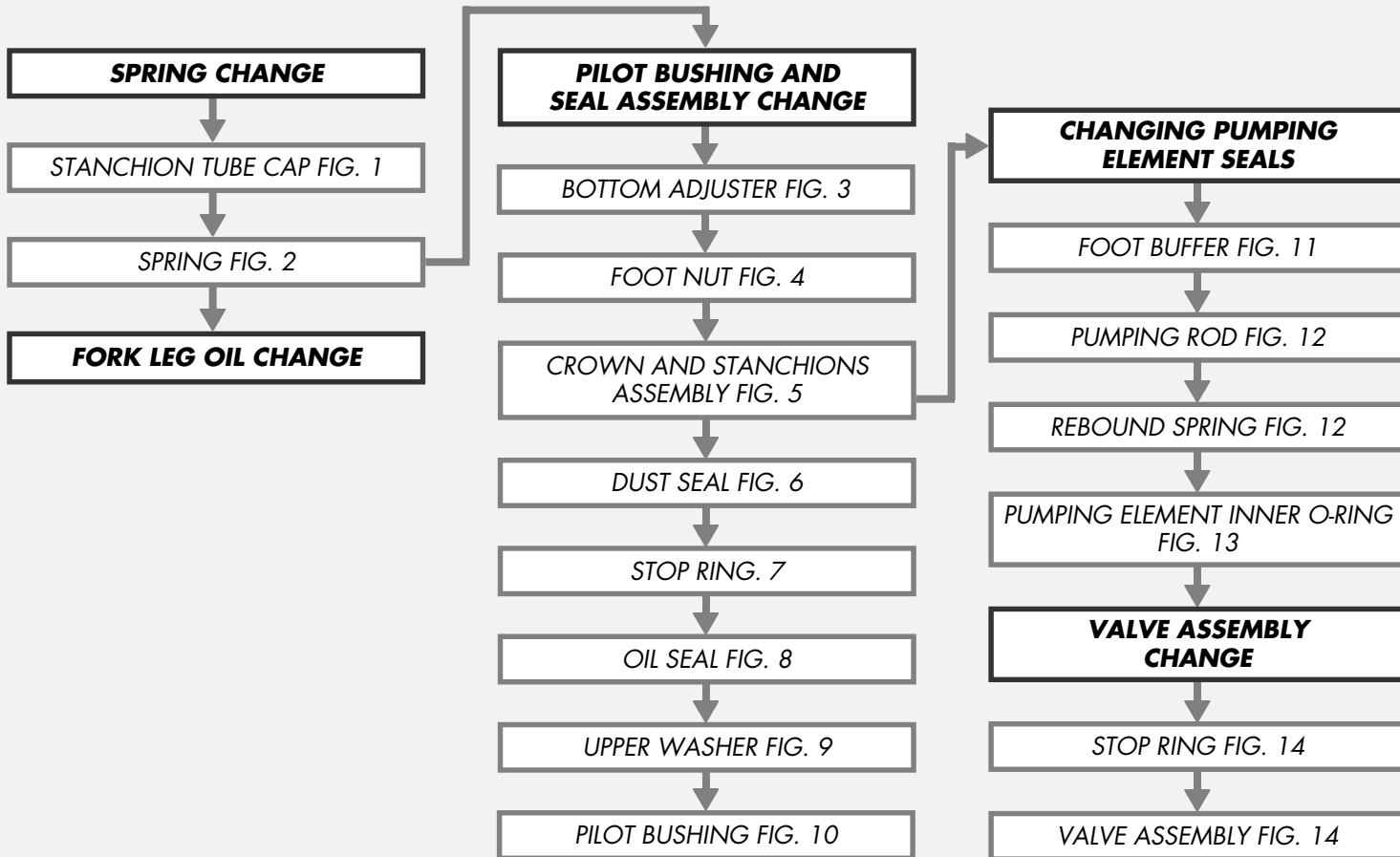

Z3

QR20

SPRING CHANGE

FIG. 1

Unscrew the caps (4) with a 21 mm socket wrench.

Remove the caps complete with O-ring (5) from the stanchions.

FIG. 2

Push the stanchions into the sliders and remove the lower washer (11) and the spring (34) from each fork leg.

Drain all oil from the fork legs.



WARNING: Remember to always recycle any used oil.

To change the fork leg oil follow the procedure as described in section "REASSEMBLY" from Fig. 27 to Fig. 29.

PILOT BUSHING AND SEAL ASSEMBLY CHANGE

FIG. 3 (only right leg)

Turn fork legs upside down and press adjuster retainer (28) with a small screwdriver to release it. Remove adjuster assembly (28) from the slider.

Z3
QR20

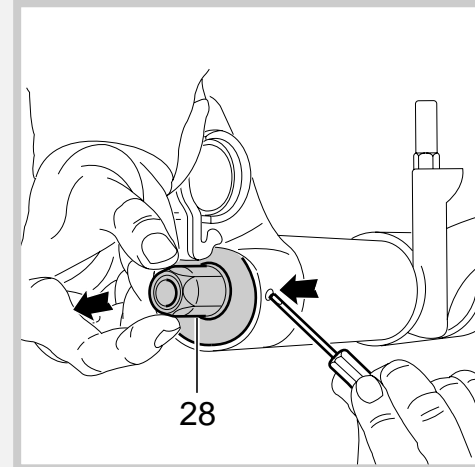
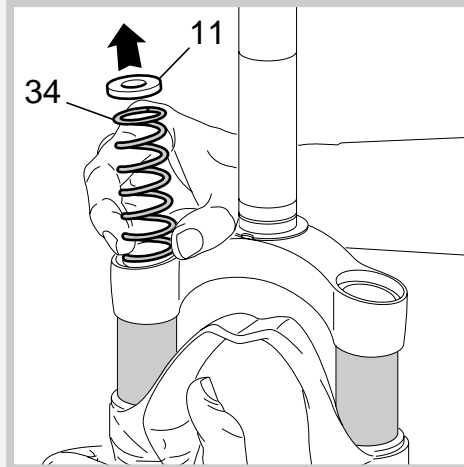
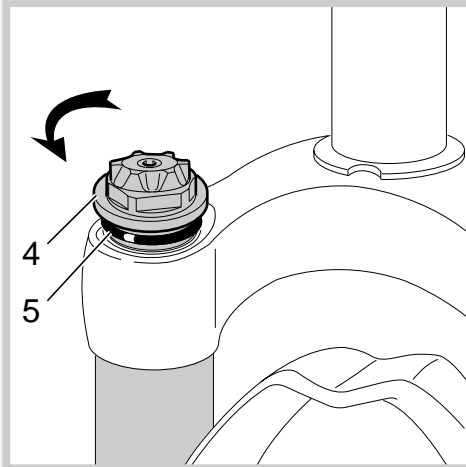

FIG. 4

Remove foot nuts **(26)** and **(29)** with a socket wrench.

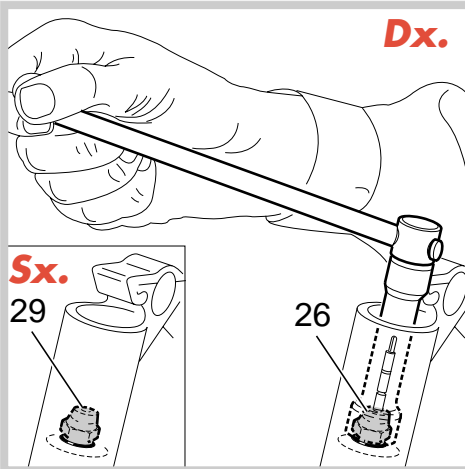

FIG. 5

Withdraw the crown and stanchions assembly **(1)** from the sliders.

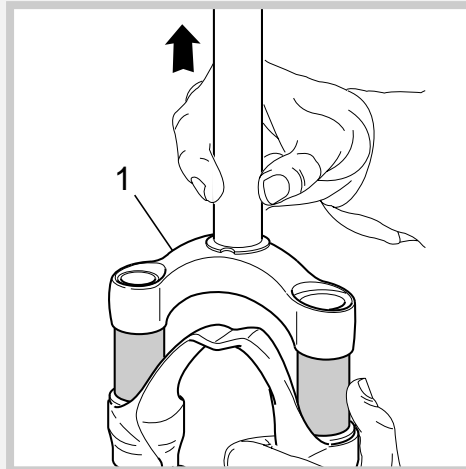
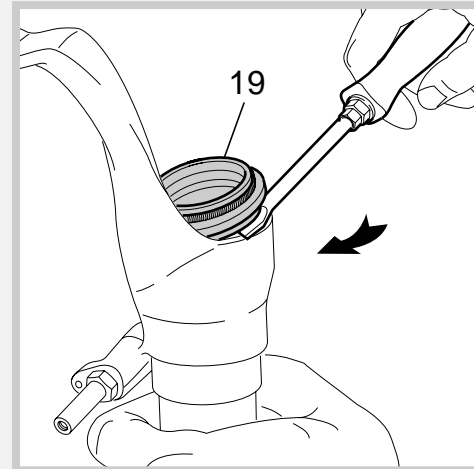

FIG. 6

Remove the dust seal **(19)** from the top of the sliders using a small screwdriver.



Z3

QR20

FIG. 7

Remove the stop ring (20) from the sliders by placing the screwdriver bit in one of the three openings on the stop ring.

IMPORTANT: when removing the stop ring, make sure not to damage its seat.

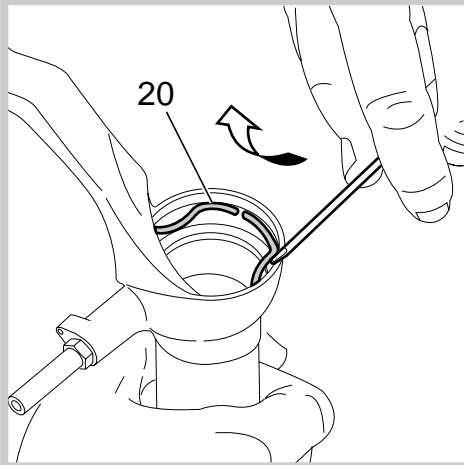
**FIG. 8**

Fit the slider protector (A) onto the slider and remove the oil seal (21) with the help of a large screwdriver.

IMPORTANT: when removing the oil seal, make sure not to damage its seat. Once removed the oil seals should not be used again.

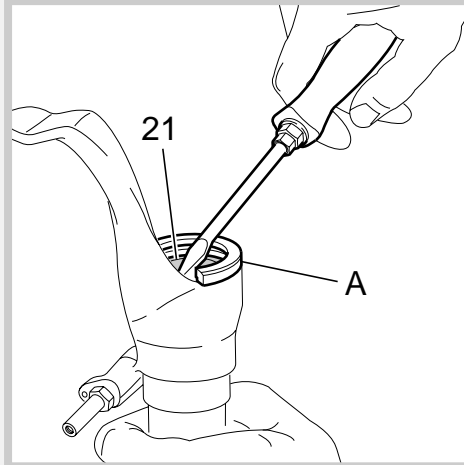
**FIG. 9**

Remove the upper washer (22) from the slider.

**Z3****QR20**

FIG. 10

Fit the bit of a small screwdriver into upper edge slot of the pilot bushing (23) and lift gently. Pull the bushing out of the slider and make all necessary changes.

REPLACING PUMPING ELEMENT SEALS

FIG. 11

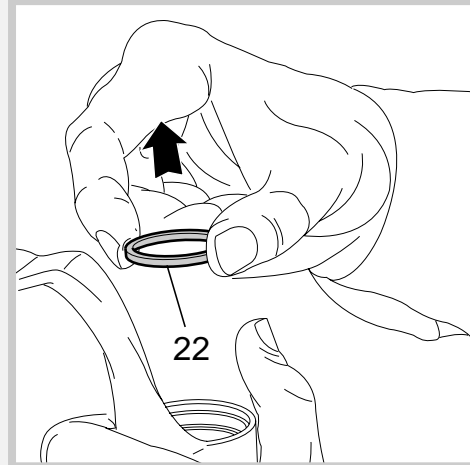
Remove the foot buffer (18) complete with ring (25) from the pumping rod ends (14) and (12).

FIG. 12

Withdraw the pumping elements (14) and (12) and the rebound spring (15) from the stanchion tube top. Replace the seal ring (13) if damaged or worn out.

**Z3
QR20**

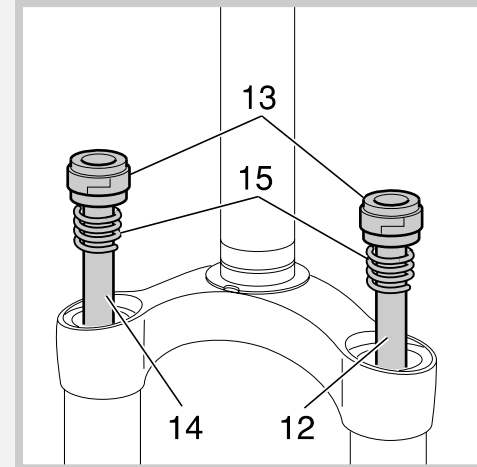
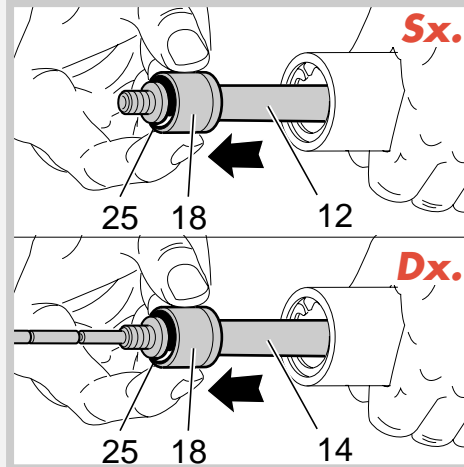
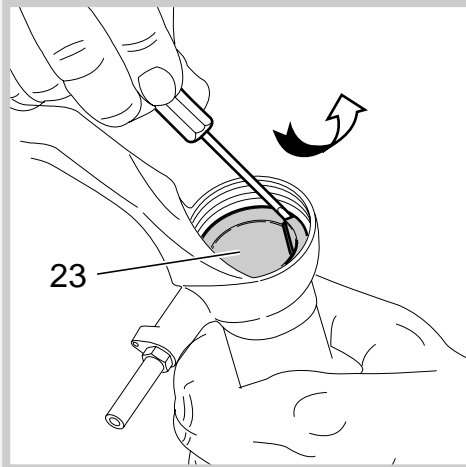

Z3

QR20

FIG. 13 (only right leg)

Remove the stop ring (33) from pumping element bottom (14) with a small flat screwdriver.

Mark stop ring seat into inner rod for proper fitting.

Use the same screwdriver to remove the ring (A) and screw inner rod until adjuster threaded end is disengaged from pumping element.

Remove inner rod and replace O-ring (27) if damaged.

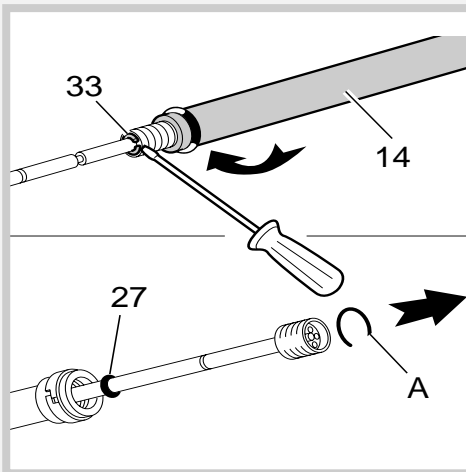

VALVE ASSEMBLY CHANGE

FIG. 14

To check that the valve assembly is operating correctly, it is necessary to work on the inside of the stanchion tube.

Slip off the stop ring (17) using pointed pliers.

Pull the valve assembly (16) out of the tube with one finger in the same sequence as in the figure.

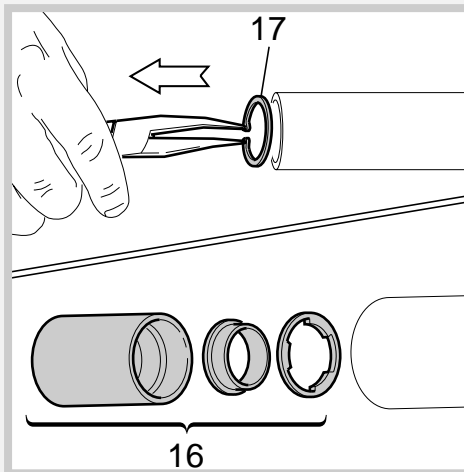

REASSEMBLY

CAUTION: before reassembling, all metal components should be washed carefully with inflammable, preferably biodegradable, solvent and dried with compressed air.

PILOT BUSHING AND SEAL ASSEMBLY

FIG. 15

Check that no dirt or debris is between slider and bushing. Insert the pilot bushing (23) into place so that it adheres to the slider.

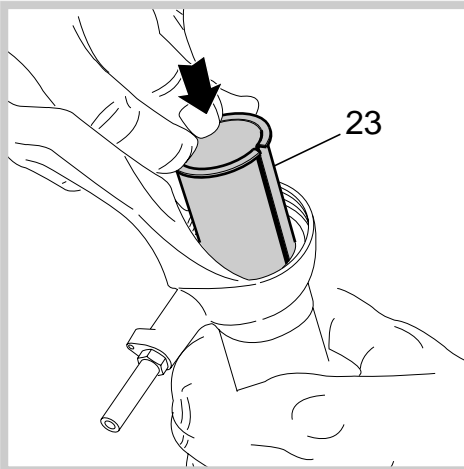

FIG. 16

Fit the upper washer (22) into the slider so that it touches the pilot bushing.

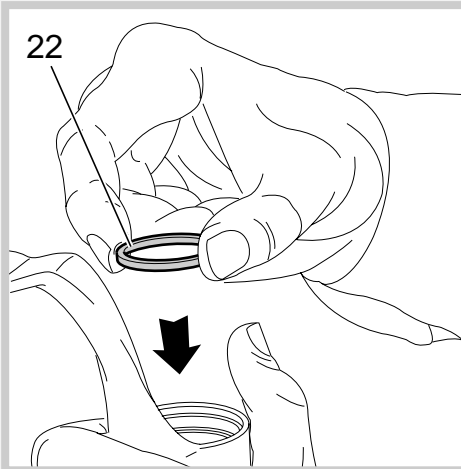
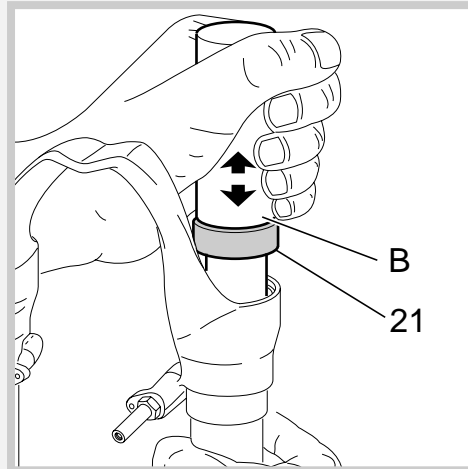

FIG. 17

Lubricate the oil seal (21) and place it onto the seal press (B) with the hollow side toward the slider. Press the oil seal until it touches the lower washer by using the above seal press.



Z3

QR20

FIG. 18

Insert the stop ring (20) into the slider making sure it is properly seated into place.

Use buffer (B) to properly seat the ring into the slider.

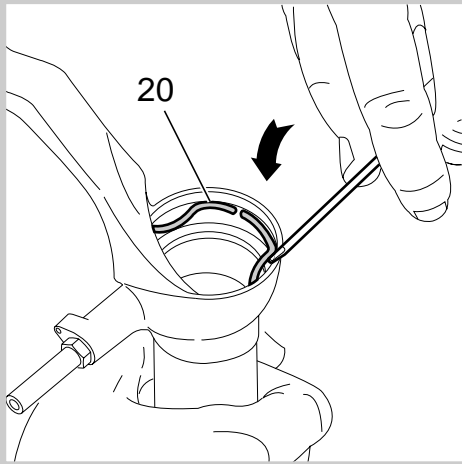
**FIG. 19**

Lubricate the dust seals (19) and fit them into the stanchions from the spring end.

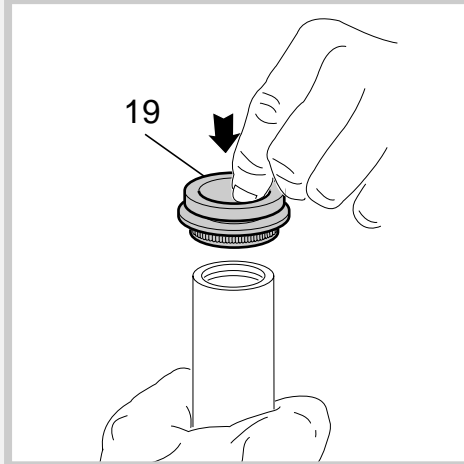
**PUMPING ROD ASSEMBLY****FIG. 20 (only right leg)**

Lubricate the O-ring (27) and fit inner rod threaded end into pumping element (14). Turn inner rod clockwise so that threaded end can be seen into pumping element and stop ring seat (33), marked during disassembly.

Installez la bague de butée (33) dans le logement sur la tige interne et la bague (A) dans le logement sur la tige amortisseur.

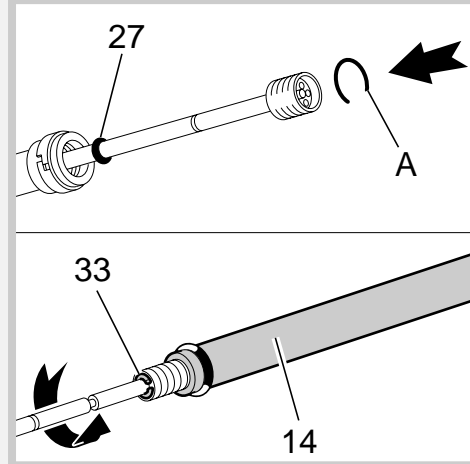
**Z3****QR20**

VALVE AND PUMPING ROD ASSEMBLY

FIG. 21

After having overhauled or replaced the valve unit and after having cleaned the inside of the tube, reassemble. Assemble valve components (16), in correct sequence.

Then fit pumping elements (12) and (14) with seal ring (13) and rebound spring (15) into the valve assembly (16).

FIG. 22

Lubricate the O-rings (24-25) and reassemble the foot buffer (18) onto pumping element ends (14) and (12).

FIG. 23

Fit this assembly into the stanchion tube and properly seat the valve assembly (16).

Insert the stop ring (17).

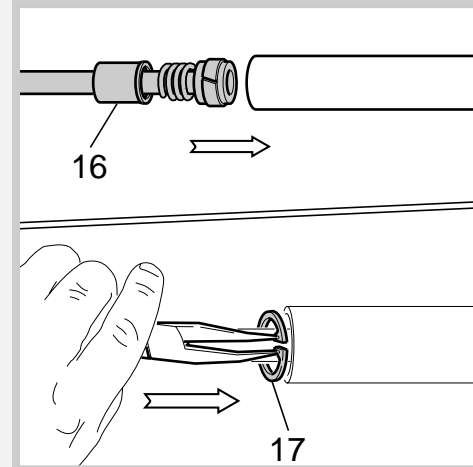
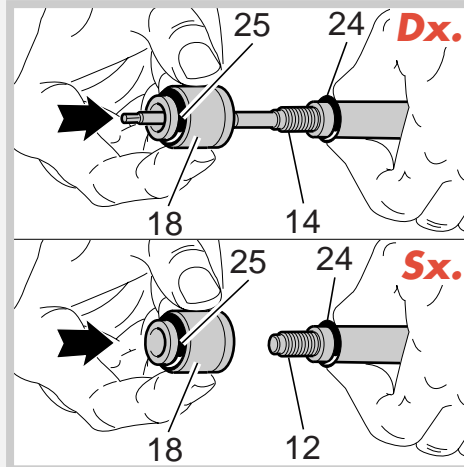
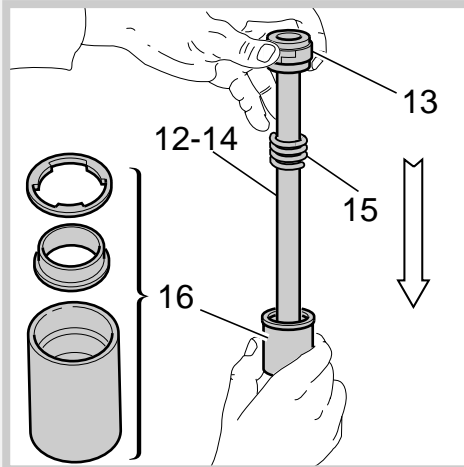

Z3

QR20

CROWN AND STANCHIONS ASSEMBLY

FIG. 24

Fit the crown and stanchions assembly (1) - with the dust seals in place - gently into the sliders seals.

IMPORTANT: to avoid any damages to sealing surfaces, keep the stanchions duly lubricated and squared into the sliders.

Press the crown and stanchions assembly fully down and check that threaded ends of pumping elements (14) and (12) are coming out through the bottom of the sliders. Check to see that the stanchions slide unrestricted by cycling the fork up and down several times.

The tube should slide freely inside the seal assembly without any side play. In the event it is too hard or too soft, repeat the previous steps described above and check components to ensure they are not damaged. Seat the dust seals (19) on top of the sliders.

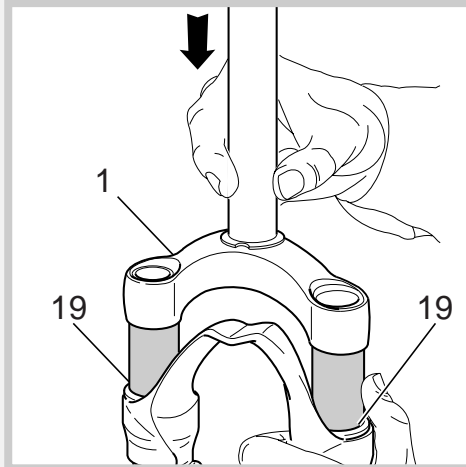

FIG. 25

Screw the foot nuts (26) and (29) on the threaded elements of pumping elements (14) and (12).

Tighten to 12 Nm.

Check to verify that the stanchions slide properly through the stroke by pumping them up and down several times.

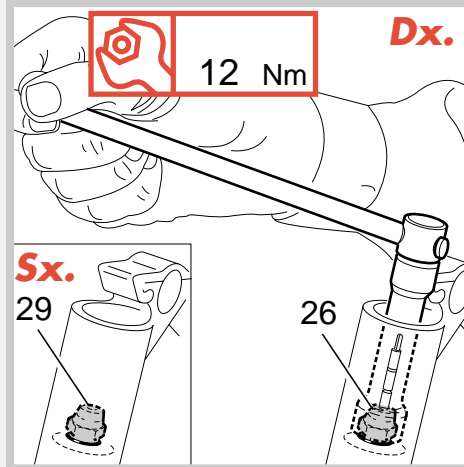
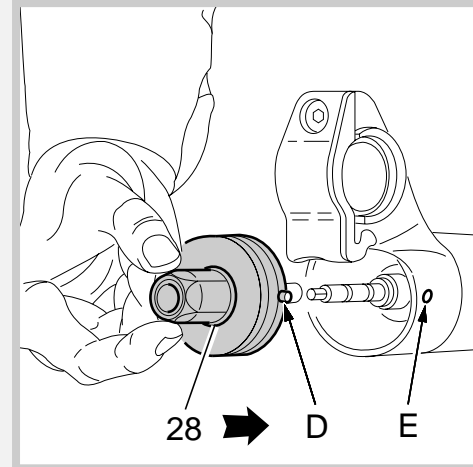

FIG. 26

Fit the retainer (D) into the slider (E) to reassembly the adjuster unit (28).



Z3

QR20

HOW TO FILL WITH OIL

FIG. 27

Pour oil little by little when the stanchions are fully down and then pump with the crown so as to have a better filling. Ensure proper oil level (**H**), from the top of the stanchion tube, in both legs.

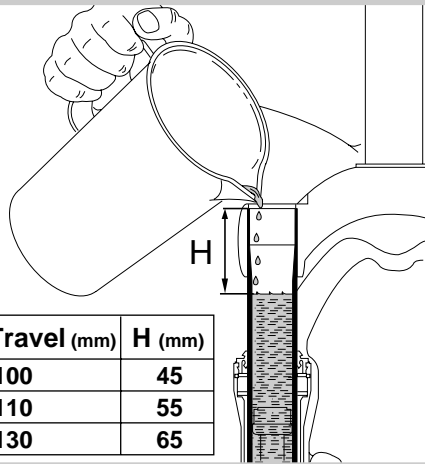

SPRING AND CAP

FIG. 28

Fit the springs (**34**) into each stanchion tube.

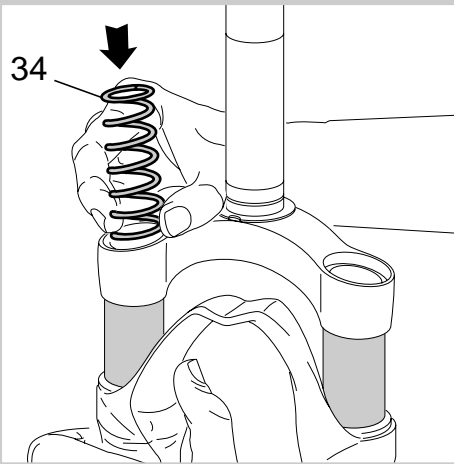
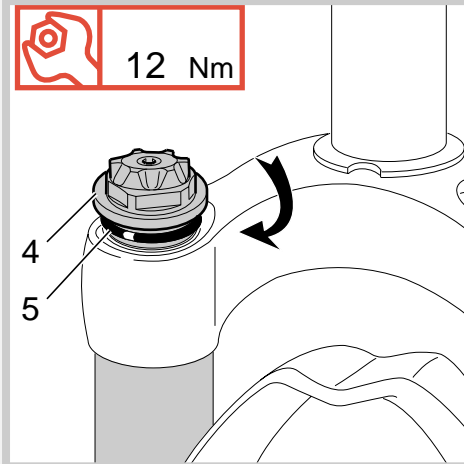

FIG. 29

Lubricate the O-ring (**5**) on the cap (**4**). Turn the preload adjuster (**9**) counterclockwise until it is at its minimum setting and install the lower washer (**11**). Start the caps with the O-ring (**5**) in place into the stanchion tube threads by hand. Tighten caps (**4**) to 12 Nm.



Z3

QR20

SPECIFIC MARZOCCHI TOOLS

<i>Ref.</i>	<i>Item.</i>	<i>Description and use</i>
A	R 5089 AB	Slider protector: to remove the oil seal from the slider
B	R 5090	Oil seal press: to press oil seal into the slider

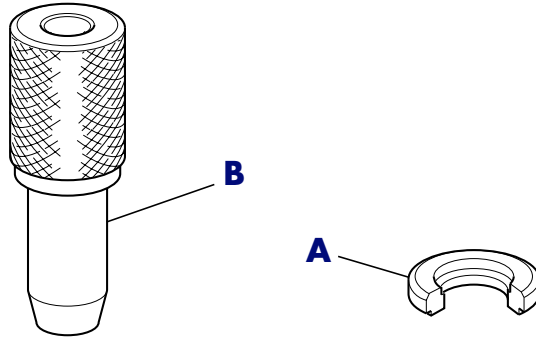

Z3
QR20